

*XITRON TECHNOLOGIES*

USER'S GUIDE

2551/2551E

Single-Phase

Power Analyzer



# Warranty

The Xitron Technologies instrument is warranted against defects in material and workmanship for a period of two years after the date of purchase. Xitron Technologies agrees to repair or replace any assembly or component (except batteries) found to be defective, under normal use, during the warranty period. Xitron Technologies' obligation under this warranty is limited solely to repairing any such instrument which in Xitron Technologies' sole opinion proves to be defective within the scope of the warranty, when returned to the factory or to an authorized service center. Transportation to the factory or service center is to be prepaid by the purchaser. Shipment should not be made without prior authorization by Xitron Technologies.

The warranty does not apply to any products repaired or altered by persons not authorized by Xitron Technologies, or not in accordance with instructions provided by Xitron Technologies. If the instrument is defective as a result of misuse, improper repair, or abnormal conditions or operations, repairs will be billed at cost.

Xitron Technologies assumes no responsibility for its product being used in a hazardous or dangerous manner, either alone or in conjunction with other equipment. Special disclaimers apply to this instrument. Xitron Technologies assumes no liability for secondary charges or consequential damages, and, in any event, Xitron Technologies' liability for breach of warranty under any contract or otherwise, shall not exceed the original purchase price of the specific instrument shipped and against which a claim is made.

Any recommendations made by Xitron Technologies or its Representatives, for use of its products are based upon tests believed to be reliable, but Xitron Technologies makes no warranties of the results to be obtained. This warranty is in lieu of all other warranties, expressed or implied, and no representative or person is authorized to represent or assume for Xitron Technologies any liability in connection with the sale of our products other than set forth herein.

Instrument Serial Number: \_\_\_\_\_

Document Part Number: MO-2551/2551E-M Revision E

Print date: January 31, 2006

## Copyright

Copyright© 1998 - 2000 Xitron All rights reserved.

All rights reserved. No part of this publication may be reproduced, transmitted, transcribed, stored in a retrieval system, or translated into any language in any form without prior written consent from Xitron Technologies. This product manual is copyrighted and contains proprietary information, which is subject to change without notice. The product's displays and manual text may be used or copied only in accordance with the terms of the license agreement.

*XITRON TECHNOLOGIES* is a trademark of Xitron Technologies. All other trademarks or registered trademarks are acknowledged as the exclusive property of their respective owners.

In the interest of continued product development, Xitron Technologies Inc., reserves the right to make changes in this guide and the product it describes at any time, without notice or obligation.

## Xitron Technologies Incorporated

9770-A Carroll Centre Rd  
San Diego, California 92126  
Telephone: (858) 530-8099  
Fax: (858) 530-8077

E-mail: [sales@xitrontech.com](mailto:sales@xitrontech.com)  
E-mail: [support@xitrontech.com](mailto:support@xitrontech.com)



ISO-9001: 2000  
Cert. No. A0001474-1

# Contents

<b>INTRODUCTION</b>	<b>11</b>
<b>Scope</b>	<b>11</b>
<b>Features</b>	<b>12</b>
<b>FUNCTIONAL DESCRIPTION</b>	<b>13</b>
<b>Theory of Operation</b>	<b>13</b>
<b>Interfaces</b>	<b>15</b>
Front Panel	15
Parallel Printer	15
IEEE488	16
<b>USING THE POWER ANALYZER</b>	<b>17</b>
<b>Setting Up</b>	<b>17</b>
<b>Front Panel</b>	<b>18</b>
<b>Rear Panel Connections</b>	<b>19</b>
<b>Starting the Power Analyzer</b>	<b>20</b>
<b>Configuring the Power Analyzer</b>	<b>20</b>
<b>Measurement Connections</b>	<b>24</b>
Using the Internal Current Transducer	25
Using an External Current Transducer	26
<b>SEQUENCE OF DISPLAY SCREENS</b>	<b>29</b>
<b>Using the Diagrams</b>	<b>29</b>
<b>Diagrams</b>	<b>30</b>
<b>VIEWING RESULTS</b>	<b>35</b>
<b>Display Screens</b>	<b>35</b>

Basics Group _____	36
Rectified _____	38
Harmonics Group _____	40
Waveforms Group _____	43
History Group _____	45
<b>PRINTING RESULTS _____</b>	<b>49</b>
<b>Sample Printouts _____</b>	<b>49</b>
<b>CALIBRATION _____</b>	<b>63</b>
<b>Removing DC Current Offsets _____</b>	<b>63</b>
<b>Calibrating the Power Analyzer _____</b>	<b>65</b>
<b>Calibration Procedures _____</b>	<b>65</b>
Voltage Calibration _____	67
Current Calibration _____	69
<b>Calibration Faults _____</b>	<b>71</b>
<b>APPENDIX A - PHYSICAL SPECIFICATIONS _____</b>	<b>73</b>
Temperature & Humidity _____	73
Size & Weight _____	73
Power Input _____	73
<b>APPENDIX B – MEASUREMENT SPECIFICATIONS _____</b>	<b>75</b>
Power Source Capabilities (Option E only) _____	75
Input Signal Capabilities _____	75
Input Burden _____	76
Measurement Accuracy _____	76

# Figures

Figure 1. Bench Type Power Analyzer _____	17
Figure 2. Front Panel detail _____	18
Figure 3. Rear Panel detail _____	19
Figure 4. Startup screen _____	20
Figure 5. Setup Index screen with INTERFACES/DATE/TIME selected _____	21
Figure 6. The Interface Setup screen _____	21
Figure 7. Setup Index screen with MEASUREMENTS selected _____	22
Figure 8. The Measurement Setup screen _____	22
Figure 9. Setup Index screen with CURRENT INPUT selected _____	23
Figure 10. The Current Input Setup screen _____	23
Figure 11. Setup Index screen with PRODUCT OPTIONS FITTED selected _____	24
Figure 12. The Options Fitted screen _____	24
Figure 13. Test Device Connections _____	25
Figure 14. 2551/2551E Internal Effective Circuit (shown for reference) _____	25
Figure 15. External Transducer Test Connections _____	26
Figure 16. Sample Basics display screen _____	29
Figure 17. Basic $\Sigma$ RMS sample _____	30
Figure 18. Harmonics Listing and Bargraph samples _____	31
Figure 19. Waveforms V&A DIST sample _____	32
Figure 20. History VOLTS PEAK sample _____	33
Figure 21. $\Sigma$ RMS MEAS display with callouts _____	36
Figure 22. $\Sigma$ RMS INRUSH display _____	36
Figure 23. $\Sigma$ RMS INTEGRATED display with callouts _____	36

Figure 24. $\Sigma$ RMS INTEG AVG display _____	37
Figure 25. Basics DC MEAS display _____	37
Figure 26. Basics DC INRUSH display _____	37
Figure 27. Basics DC INTEGRATED display _____	37
Figure 28. Basics DC INTEG AVG display _____	38
Figure 29. Basics DC LOAD display with callouts _____	38
Figure 30. Basics RECTIFIED MEAS display with callouts _____	38
Figure 31. RECTIFIED INRUSH display _____	38
Figure 32. Basics FUND MEAS display with callouts _____	39
Figure 33. Basics FUND LOAD display _____	39
Figure 34. $\Sigma$ HARMS display with callouts _____	39
Figure 35. Harmonics LISTING ABS display _____	40
Figure 36. Harmonics LISTING PCT display _____	40
Figure 37. Harmonics LISTING PHASE display _____	40
Figure 38. Harmonics AMPS ABS Lin display with callouts _____	41
Figure 39. Harmonics AMPS ABS Log display _____	41
Figure 40. Harmonics AMPS % Lin display _____	41
Figure 41. Harmonics AMPS % Log display _____	41
Figure 42. Harmonics VOLTS ABS Lin display _____	42
Figure 43. Harmonics VOLTS ABS Log display _____	42
Figure 44. Harmonics VOLTS % Lin display _____	42
Figure 45. Harmonics VOLTS % Log display _____	42
Figure 46. Waveforms V&A CONT display with callouts _____	43
Figure 47. Waveforms V&W CONT display _____	43
Figure 48. Waveforms V&A DIST display with callout _____	43
Figure 49. Waveforms V PEAK display with callout _____	44
Figure 50. Waveforms A PEAK display with callouts _____	44
Figure 51. Waveforms V GLITCH display _____	44
Figure 52. Waveforms A GLITCH display _____	44
Figure 53. History VOLTS RMS display with callouts _____	45
Figure 54. History VOLTS PEAK display _____	45



Figure 55. History VOLTS ENVELOPE display _____	45
Figure 56. History VOLTS % THD display _____	45
Figure 57. History AMPS RMS display _____	46
Figure 58. History AMPS PEAK display _____	46
Figure 59. History AMPS ENVELOPE display _____	46
Figure 60. History AMPS % THD display _____	46
Figure 61. History WATTS display _____	46
Figure 62. History VAR display _____	47
Figure 63. History PF display _____	47
Figure 64. Basic Measurement sample printout _____	51
Figure 65. Harmonics Data List sample printout _____	52
Figure 66. Current Harmonics Barchart sample printout _____	53
Figure 67. Current Harmonics Barchart sample printout _____	54
Figure 68. Volts, Amps, Power Waveforms sample printout _____	55
Figure 69. Volts and Amps Waveforms nongraphic sample printout _____	56
Figure 70. Volts Glitch Capture sample printout _____	57
Figure 71. Amps Peak Capture sample printout _____	58
Figure 72. Distortion Waveforms sample printout _____	59
Figure 73. Voltage Level History sample printout _____	60
Figure 74. Voltage Level History nongraphic sample printout _____	61
Figure 75. . Setup Index screen with Current Inputs selected _____	63
Figure 76. INPUT SELECTION selected _____	64
Figure 77. CALIBRATION selected _____	64
Figure 78. DC ZERO Date selected _____	64
Figure 79. Calibration selected _____	66
Figure 80. Calibration Date selected _____	66
Figure 81. Open Circuit Point prompt _____	66
Figure 82. Voltage Point Initial display _____	67
Figure 83. External Voltage Point display _____	68
Figure 84. Voltage Point Zero Readings _____	68
Figure 85. Internal Current Cal Point display _____	69

Figure 86. Load L Current Cal Point display _____	69
Figure 88. External Transducer Current Cal Point display _____	70
Figure 87. Calibrations Successful display _____	70

---

# Introduction

The purpose of this user guide is to describe the use and capabilities of the 2551 and 2551E (External Current) Single-Phase Power Analyzers.

## Scope

The single-phase 2551/2551E is an easy-to-use, general purpose power analyzer. Overall, the 2551/2551E analyzes the electrical power delivered to or by a device. The unit can be quickly set up on your bench top. You can adjust the viewing angle using the handle and adjust the contrast from the configuration screen.

The 2551E provides support for an external current transducer of the current:current or current:voltage type. This option also provides receptacles at the rear panel allowing the user to power external circuitry from the 2551's internal DC power supplies (positive and negative 15V).

Both the 2551 and 2551E analyzers display voltage, current and wattage results in numeric and graphic waveform formats. Results include voltage, current and wattage, high and low peaks and harmonic frequencies in absolute, percentage and phase. You may display the harmonics in a bargraph format through the 40<sup>th</sup> harmonic or in a listing format through the 50<sup>th</sup> harmonic. You may examine power waveform distortion and glitches graphically and chart historical results in divisions of time from seconds to days. Additional screens display voltage and current envelopes, harmonics, averages, reactive power, integrated results, K-factor, power factor and crest factor of the voltage or current signal.

All of the data that can be displayed on the 2551/2551E screens can be printed in full-page printout formats. Refer to *Printing Results* page 49. Note that both bargraph and listing fundamental printouts contain the 2<sup>nd</sup> through the 50<sup>th</sup> harmonics.

Note: For further information on Xitron Technologies' measurement techniques and formulas used please refer to the Methods Guide. Please contact Xitron Technologies for a copy or visit our support page at [www.xitrontech.com](http://www.xitrontech.com)

## Features

The 2551/2551E Power Analyzers' features include the following—

- A simple interface.
- Display basic measurements of  $\Sigma$ RMS, DC, fundamental (harmonic), and  $\Sigma$ Harmonics for any single phase.
- Displays harmonics in bargraph or a list format.
- Continuously updated displays of voltage, current and wattage waveforms.
- Displays waveforms of voltage and current distortion, peaks and glitches.
- Displays historic results for voltage and current, watts, reactive power and power factor.
- Allowances for scaling of all current readings by a numerical factor.
- Provides adjustable display contrast.
- All measurements are performed and updated on each measurement cycle all of the time, this ensures that you are testing your product in real-time.

---

# Functional Description

This chapter describes the circuitry and interfaces of the 2551/2551E.

## Theory of Operation

The 2551/2551E are high performance test equipment. Within the analyzer, voltage and current signals are converted to digital data where the signals are sampled automatically and periodically. A/D converters scale and sample data. The DSP components analyze voltage and current input samples for harmonic content.

The following is a list of the significant components and a description of their function within the analyzer.

**Voltage Attenuators**—Resistively attenuate the voltages present on the SOURCE L (A) and N terminals to a 2.5V peak amplitude maximum voltage signal.

**Hall Effect Transducer**—Converts the current flowing from SOURCE to LOAD into an isolated voltage of the 2551/2551E.

**Analog Anti-Alias Filters**—Reduce the bandwidth of the signals applied to the inputs of the ADCs to less than the sampling frequency.

Each of the attenuator's outputs and the output of the Hall Effect transducer are passed through identical analog anti-alias filters.

**16-Bit A to D converters (ADC) and First In/First Out memory (FIFO)**—

The ADCs digitize each signal with 16-bit resolution at the DSP generated Sample Clock frequency. The FIFOs store each digital sample in memory to be read by the DSP in blocks of 32 samples per converter.

**Digital Signal Processor (DSP)**—Processes the tasks required to compute the multiple voltage, current, and power results. Also processes the tasks required to format the results for display, printout and interrogation via the IEEE488 interface. Computed results are independent of the selected display and IEEE488 interface requirements.

The DSP generates a sample-clock signal from the computed frequency of the user-selected synchronization source. The sample-clock signal clocks the ADCs at a suitable frequency to ensure exact synchronization of the overall measurements to the applied signals. The sampling frequency may be up to 220kHz and is slightly "dithered" to ensure that individual samples cannot be exactly at the same phase of the applied signals, while maintaining exact synchronization for the overall measurement period.

The samples read from the FIFOs are passed through one to three stages of 6-pole elliptical filters. (The stage of filtering is dependent on user-selected configuration and bandwidth of harmonics measurements.) The first stage filters the samples for all nonharmonic measurements. The second stage is anti-alias filtering of the samples for the DFT and waveform collection. The third stage filters the samples for waveform period measurements to display the synchronized results.

All measurements are made nominally over four cycles of the applied signal and then two-pole filtered with a user-selected averaging filter to produce fast, yet stable, measurement results. (Note that there are more cycles at very high frequencies and less at very low frequencies.)

Historical results are maintained by the DSP from the unfiltered measurement results. Harmonics results, both amplitude and phase, are computed by the DSP by means of a variable length Discrete Fourier Transform (DFT). Nominally 400 equally spaced samples per cycle are also collected for waveform display purposes.

At nominal line frequencies and below, all measurements are continuous, there being no missed portions of the signal in any of the resultant measurements. At very high frequencies "gaps" can only result in the harmonics measurements.

The DSP also contains 4Kx24 of internal RAM for working memory, 3Kx24 of program memory and a 1Kx24 level 1 cache memory.

The DSP can perform one arithmetic operation and two data movements per 12.5ns, yielding 80MIPs for arithmetic operations and 240MIPs overall capability.

**IEEE488 Interface**—Performs the majority of the bus interface details for the IEEE488 protocol. All IEEE448 interfacing is done with data output from the DSP, or data and commands input to the DSP. This interface is controlled using a commercially available IC (National Instruments TNT488).

**Parallel Printer Interface**—This IC performs the majority of the bus interface details for the parallel printer protocol. The data to be output over the interface comes from the DSP. This interface is controlled using a commercially available IC.

- Graphical Display Module**—Allows a visual reading of the results in alphanumeric and/or graphical format. The display screen is a commercially available LCD with 240x64 pixels and a CCFL backlight. All graphical information for the screens is generated by the DSP.
- Keyboard**—Allows for changing and bringing up the various displays of results. The keyboard is formed by six key switches, each individually readable by the DSP. All actions taken as a result of a key being pressed are generated by the DSP.
- Real Time Clock (RTC) and Non-Volatile Memory (NVRAM)**—Generates the date and time of day information, and also stores the user display configuration, the IEEE488 address, and the calibration data for each input. Both clock and memory are within a single commercially available IC.
- Random Access Memory (RAM)**—A total of 256Kx24, 15ns access time memory is available to the DSP to store all "working" information, all computed results, formatted printout data and display pixels. This memory also contains the software program for the DSP, copied from the Flash memory.
- Flash Program Memory**—This memory is rewritable Flash memory used for DSP program storage. The program is copied into RAM following application of power and is CRC checked for integrity. After being copied into RAM, the Flash memory is not used during normal operation.

## Interfaces

*Note: Specifications are subject to change without notice.*

### Front Panel

#### Liquid Crystal Display—

240 x 64 High-speed graphics LCD with CCFL Backlight (5" x 1.35" viewing area)

**Keyboard**—Two fixed-purpose keys + four softkeys

### Parallel Printer

**Printer Interface**—Parallel IEEE1284

**Format**—Unformatted text or PCL (user selectable)

**Data Rate**—Up to 1000 characters per second (limited by printer)

**Compatible Printers—**

Text: any 80 character wide (or more) by 66 character long (or more) ASCII parallel text printer  
PCL: Hewlett-Packard DeskJet family, Hewlett-Packard LaserJet family, other PCL level two (or higher) compatible parallel printer with 75dpi or greater raster graphics print resolution

**IEEE488****Interface—**

IEEE488.1 (Certain commands conform to IEEE488.2)

**Addressing—**

Single address, user selectable via front panel between 0 and 29 inclusive

**Capabilities—**

SH1 AH1 T6 L4 SR1 RL1 PP0 DC1 DT1 C0 E2 (350ns min. T1)

**Max. Talk Data Rate—**

>300,000 bytes per second

**Max. Listen Data Rate—**

>100,000 bytes per second

**Command Set—**

All front panel capabilities are provided via ASCII textual command sequences.

**Results—**

Any results may be obtained at any time from the interface as ASCII textual numerical data. Additionally, status and state interrogatives are provided for on-the-fly determination of product status.



# Using the Power Analyzer

The purpose of this chapter is to describe how to set up and use the 2551/2551E. This chapter covers—

- Setting Up
- Using the Front Panel Buttons
- Rear Panel Connections
- Power Testing

## Setting Up

The Power Analyzer is made to sit on your bench. You can optimize the viewing angle by adjusting the handle and optimize the viewing brightness by adjusting the DISPLAY CONTRAST. (See *Configuring the Power Analyzer* page 20.)



Figure 1. Bench Type Power Analyzer

### ◆ To adjust the handle—

1. Press and hold the buttons located on the rear side where the handle attaches to the case sides.
2. Rotate the handle until it clicks into place.



**WARNING: IF THE POWER ANALYZER IS USED IN A MANNER NOT SPECIFIED BY XITRON TECHNOLOGIES INC., THE PROTECTION PROVIDED BY THE EQUIPMENT MAY BE IMPAIRED.**

## Front Panel

The front panel on the 2551 and 2551E includes a LCD display screen, power switch and buttons. The buttons are from left to right: NEXT, F1, F2, F3, F4 and PRINT. See below.

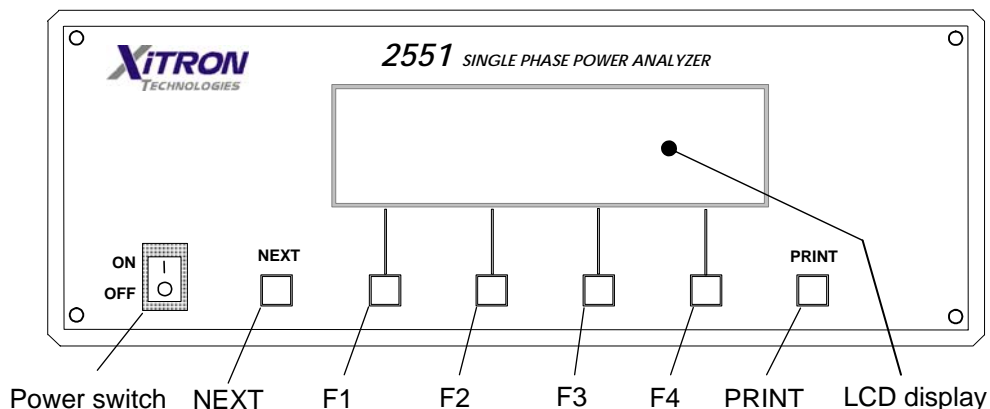

Figure 2. Front Panel detail

The screen shows the power measurement results numerically and graphically. Refer to *Viewing Results*, page 35.

The ON/OFF button powers the 2551/2551E on or off.

The NEXT button allows you to toggle through the five main display groups. Refer to *Sequence of Display Screens*, page 29.

The F1 through F4 buttons (functional softkeys) allow you to select menu choices and options. For more information, refer to *Configuring the Power Analyzer* page 20 and *Viewing Results* page 35.

The PRINT button allows you to print a full page of data reflecting the display results. A printout is formatted either graphically or by tabulation.

## Rear Panel Connections



The 2551/2551E rear panels provide connectors for a DC power jack, parallel printer cable and computer interface cable. The 2551E additionally provides an external current (BNC) connector and three transducer voltage receptacles. See below.

Available on 2551E only

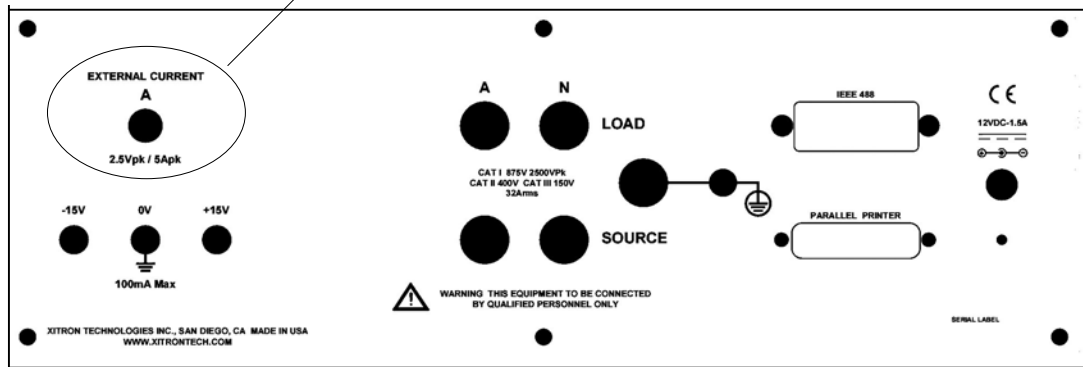

Figure 3. Rear Panel detail

### ◆ To power the 2551/2551E—

- Insert the 2.5mm DC power jack's socket end of the power cord through the supplied strain relief and into the rear panel's 2.5mm connector. Insert the plug end of the external power supply into an 85-265 volt AC, 47 - 400 Hz outlet.



**WARNING: SHOCK HAZARD. LETHAL VOLTAGES OR CURRENT MAY BE PRESENT. ENSURE NO VOLTAGE OR CURRENT EXISTS ON THESE CONNECTIONS PRIOR TO ATTEMPTING TO CONNECT TO THESE INPUT TERMINALS.**



**WARNING: IT IS RECOMMENDED THAT THE PROTECTIVE CONDUCTOR TERMINAL IS CONNECTED TO EARTH GROUND WHEN THE SIGNALS BEING MEASURED ARE REFERENCED TO EARTH GROUND.**



**THE USE OF THE T5 CHARGER FROM XITRON TECHNOLOGIES OR A XITRON TECHNOLOGIES RECOMMENDED REPLACEMENT MUST BE USED TO ENSURE THAT THE UNIT GROUND IS NOT COMPROMISED.**

### ◆ To connect a printer to the 2551/2551E—

- For printer interface, connect one end of your printer's cable to the PARALLEL PRINTER port and the other to the printer.

### ◆ To connect a PC to the 2551/2551E—

1. Attach the computer's IEEE488 cable connector to the 24-pin socket marked IEEE488 on the rear panel.

2. On the front panel, press the NEXT button until you see the main **Setup Index** display.
3. Press CURSOR until INTERFACES/DATE/TIME is highlighted.
4. Press the SETUP button. The screen changes to the Interface Setup display.
5. Press CURSOR until the IEEE ADDRESS option is selected.
6. Press the CHANGE button until the appropriate address number displays and press DONE.

## Starting the Power Analyzer

- ◆ *To start the 2551/2551E, click the ON/OFF button to the ON position.*

A startup screen will display for a few seconds. This screen lists the model number, current and voltage input options, software revision number, and firmware installation date and time.

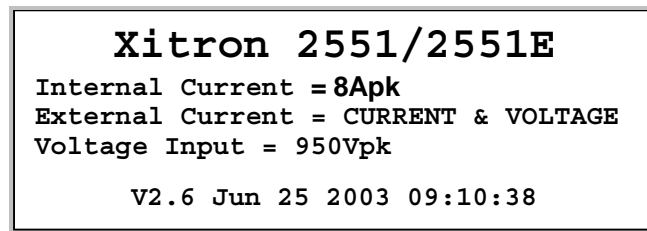

Figure 4. Startup screen

**Note:** If your unit is not calibrated, a WARNING statement will display along the top of the Startup screen stating either: “UNCALIBRATED INSTRUMENT” or “CALIBRATION DATA HAS BEEN LOST.”

The next display you will see is the same screen that displayed when the analyzer was last turned off.

## Configuring the Power Analyzer

The **Setup Index** screen gives you access to separate interface configuration screens. There is a screen for Interfaces/Date/Time; Measurements; Current Input (selection and scaling); Calibration and one to view Product Options. Refer to *Figure 5*, *Figure 7*, *Figure 9*, and *Figure 11*.

- ◆ *To reconfigure the power analyzer —*

1. Press the NEXT button until you see the main **Setup Index** screen display, as shown below.



Figure 5. Setup Index screen with INTERFACES/DATE/TIME selected

2. Press the CURSOR button to highlight the configuration item of choice and press SETUP. The screen will change to display the selected item's configuration screen.

◆ **To setup the Printer and IEEE488 address interfaces and set the date and time—**

1. With INTERFACES/DATE/TIME highlighted, press the SETUP button. The display changes to the **Interface Setup** display.

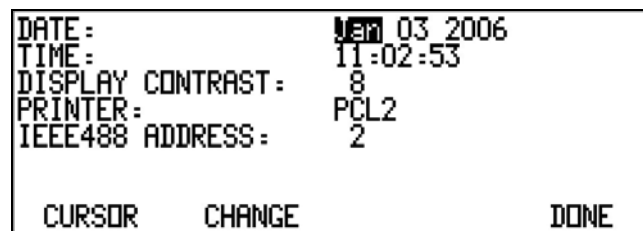

Figure 6. The Interface Setup screen

2. Use the CURSOR key to highlight any portion of the display that you desire to modify. Press the CHANGE key to change the highlighted portion of the display to the next available option for that data.

DATE = month, day, year.

TIME = (24) hours:minutes:seconds.

DISPLAY CONTRAST = 0 to 15 (default is 8)

PRINTER = PCL2; None; Text. Note that selecting *None* for the printer type disables the PRINT button in all screens.

IEEE488 ADDRESS = 1 through 29

**Note:** If you pass an option you desire, you can come back to it by continuing to press CURSOR.

3. Press the DONE key to save any changes made, and to return to the **Setup Index** screen.

◆ **To configure the measurements —**

1. From the main **Setup Index** display, press the CURSOR button to highlight MEASUREMENTS.

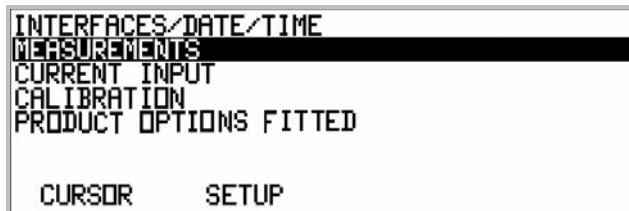

Figure 7. Setup Index screen with MEASUREMENTS selected

2. Press the SETUP button. The display changes to the **Measurements Setup** display.

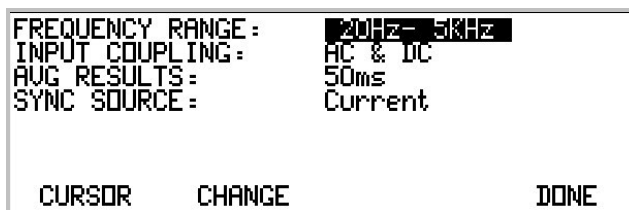

Figure 8. The Measurement Setup screen

3. Use the CURSOR key to highlight any portion of the display that you desire to modify. Press the CHANGE key to change the highlighted portion of the display to the next available option for that data. The defaults are shown in bold.

FREQUENCY RANGE = .02Hz- 20Hz; 20Hz- 100KHz; **20Hz- 5KHz**;  
2Hz- 2KHz; 0.2Hz- 200Hz

INPUT COUPLING = **AC & DC**; AC only

AVG RESULTS = 50ms; **250ms**; 1s; 2.5s; 5s; 10s; 20s; 1min

SYNC SOURCE = **Voltage**; Current; 50Hz; 60Hz; 400Hz; No Harmonics

4. Press the DONE key to save any changes made, and to return to the main **Setup Index** screen.

#### ◆ *To configure the Current Input*

The Current Input configuration screen includes selection and scaling. The current scale allows you to scale all current readings by a numerical factor. Separate scale factors are stored for each current input option, and are entered as transducer input:output ratio. This scale factor may also be negative, effectively reversing the polarity of current flow.

1. From the **Setup Index** display, press the CURSOR button twice. The CURRENT INPUT choice is now highlighted as shown below.



Figure 9. Setup Index screen with CURRENT INPUT selected

2. Press the SETUP button. The display changes to the **Current Input Setup** display. See example shown below.

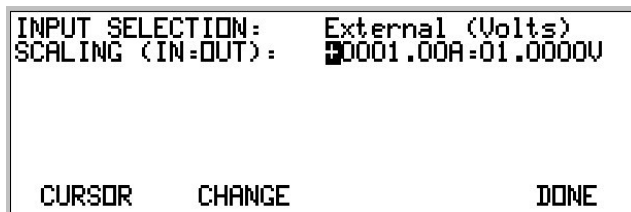

Figure 10. The Current Input Setup screen

3. Use the CURSOR key to highlight any portion of the display that you desire to modify. Press the CHANGE key to change the highlighted portion of the display to the next available option for that data.

INPUT SELECTION = External (Volts); Internal: External (Amps)

The scaling limits for current are within:

SCALING (IN=OUT) = +0000 .00A = 00.0000A through -9999 .99A = 99.9999A

The scaling limits for voltage are within:

SCALING (IN=OUT) = +0000 .00V = 00.0000V through -9999 .99V = 99.9999V

4. Press the DONE key to save any changes made, and to return to the **Setup Index** screen. Note that the scale factor for each available current input is stored separately.

**Note:** To remove DC offset and calibrate the power analyzer, refer to the Calibration section on page 63.

◆ *To view the Option Content of your Power Analyzer*

1. From the **Setup Index** display, press the CURSOR button four times. The PRODUCT OPTIONS FITTED choice is now highlighted as shown below.

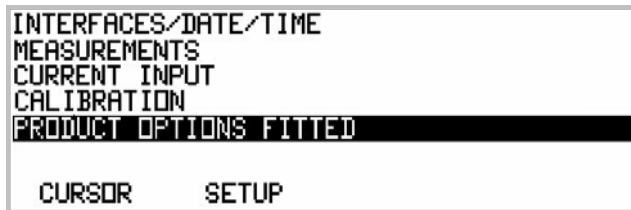

Figure 11. Setup Index screen with PRODUCT OPTIONS FITTED selected

2. Press the SETUP button. The display will show the **Product Options** screen. See an example shown below.

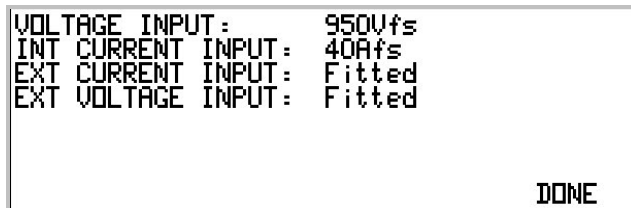

Figure 12. The Options Fitted screen

3. Press the DONE key to return to the **Setup Index** screen.

## Measurement Connections



**WARNING:** IF THE POWER ANALYZER IS USED IN A MANNER NOT SPECIFIED BY XITRON TECHNOLOGIES INC., THE PROTECTION PROVIDED BY THE EQUIPMENT MAY BE IMPAIRED.



**CAUTION:** FOR ALL CONNECTIONS, KEEP INPUT AND OUTPUT WIRING SEPARATED.



**WARNING:** IT IS RECOMMENDED THAT THE PROTECTIVE CONDUCTOR TERMINAL IS CONNECTED TO EARTH GROUND WHEN THE SIGNALS BEING MEASURED ARE REFERENCED TO EARTH GROUND.

THE USE OF THE T5 CHARGER FROM XITRON TECHNOLOGIES OR A XITRON TECHNOLOGIES RECOMMENDED REPLACEMENT MUST BE USED TO ENSURE THAT THE UNIT GROUND IS NOT COMPROMISED.



## Using the Internal Current Transducer

When using the internal current transducer of the power Analyzer, access the **Current Input Setup** screen. Set the INPUT SELECTION to *Internal* and *+1.0:1.0* for Scaling. Refer to the connections shown in *Figure 13*.

### Internal Transducer Connections for Test



Turn the source power off for the device-under-test before making each connection. Attach the test device to the input terminals on the analyzer's rear panel.

Refer to the following illustration when attaching the test device.

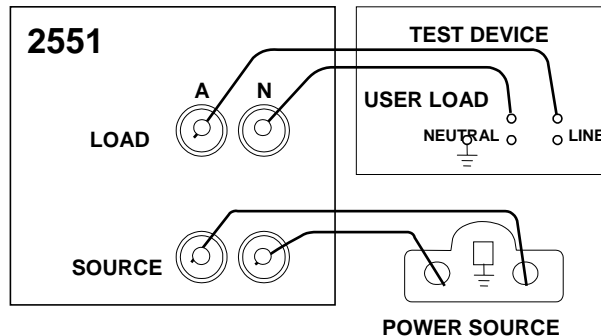

Figure 13. Test Device Connections



**WARNING: SHOCK HAZARD. LETHAL VOLTAGES OR CURRENT MAY BE PRESENT. ENSURE NO VOLTAGE OR CURRENT EXISTS ON THESE CONNECTIONS PRIOR TO ATTEMPTING TO CONNECT TO THESE INPUT TERMINALS.**

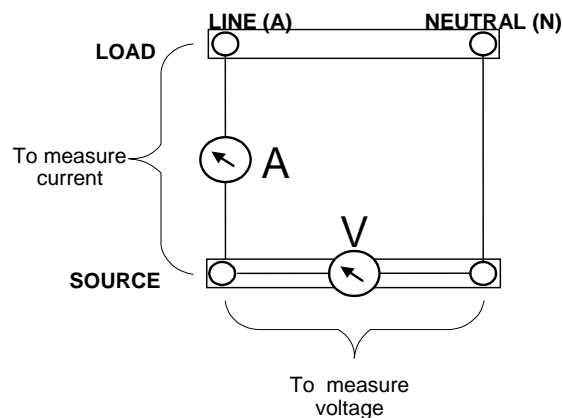

Figure 14. 2551/2551E Internal Effective Circuit (shown for reference)

## Using an External Current Transducer

When using the external current transducer, access the **Current Input Setup** screen. Select the appropriate type of current transducer (*External Amps* or *Volts*) in INPUT SELECTION and +1.0 for Scaling.

### External Transducer Connections for Test

Attach the test device to the input terminals on the analyzer's rear panel. Turn the source power off for the device-under-test before making each connection. Refer to *Figure 15*.

- Connect the power source NEUTRAL and LINE to the 2551E's Source N and L (A) terminals, respectively. These connections carry little current, therefore the wire gage may be small, however, insulate sufficiently to withstand the power source voltage.
- Connect the 2551E source N to the UUT's (Unit Under Test) NEUTRAL connection using wire sufficient to safely withstand the voltage and current drain of the load.
- Connect the 2551E source L (A) to the UUT's LINE connection using wire sufficient to safely withstand the voltage and current drain of the load.

Pass the above UUT's LINE connection wire through the current transducer with the direction of current flow being from SOURCE to LOAD. (Current flow is usually denoted by an arrow on the transducer.)

- Connect the output of the current transducer to the EXTERNAL CURRENT BNC type connector on the 2551E-rear panel.

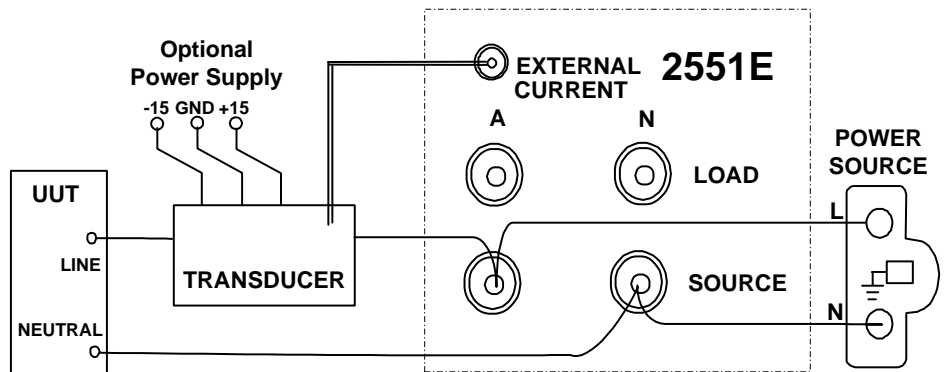

Figure 15. External Transducer Test Connections

Note the following-

1. If the power analyzer unexpectedly displays negative watts indications, these indications mean that the current flow in the transducer is reversed. Check for one of these conditions:

- the wire is reversed in the transducer;
- the neutral wire was inadvertently routed through the transducer (instead of the live wire), or;
- the transducer output has the incorrect polarity.

The negative watts indication may be resolved by correcting the wiring or by setting the current input scale factor in the power analyzer to a negative polarity.

2. If a transducer is being used which does not have DC current capability, then select *AC Only* input coupling in the **Measurements Setup** screen of the power analyzer.
3. If a transducer is being used, which has DC current capability, and the user desires to measure any DC current content, then select *AC & DC* input coupling in the **Measurements Setup** screen of the power analyzer. The user should perform the DC offset correction procedure, as described on page 63, after making the connections and allowing the external transducer to settle after application of its power.
4. Particularly when operating at low current levels, it may be important to ensure that the voltage signals cannot capacitively couple into the current transducer output. The use of flexible coaxial cable is recommended for the current transducer output wiring.



# Sequence of Display Screens

This chapter shows the sequence of the display screens in a diagram format.

## Using the Diagrams

The NEXT button takes you through the five main groups of display screens: **Setup**, **Basics**, **Harmonics**, **Waveforms** and **History**. The group names are assigned here to assist in navigating and do not display on the screen. **Setup** is used for configuring the analyzer and is described in *Using the Power Analyzer*, page 17. The other four displays are used to view results and are introduced in the following sequence diagrams. Within each main group there are various display screens that are accessible using the softkey buttons.

Refer to *Figure 16* below—

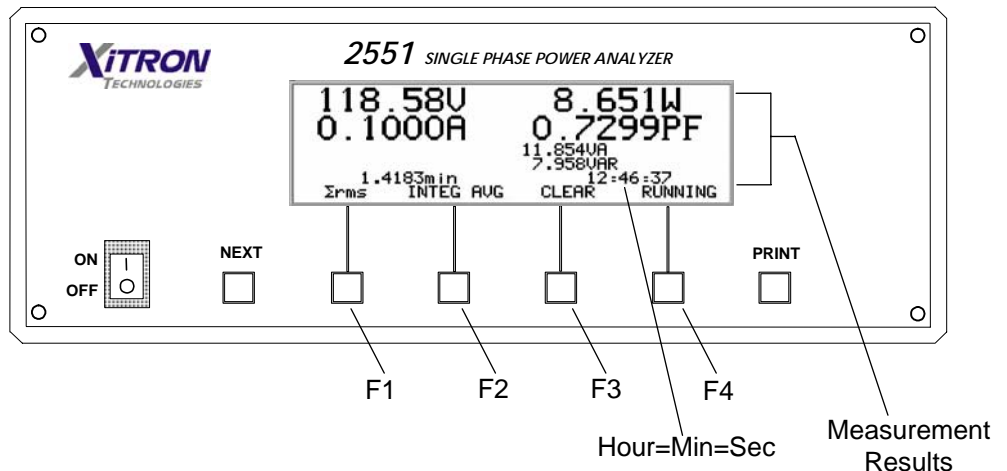
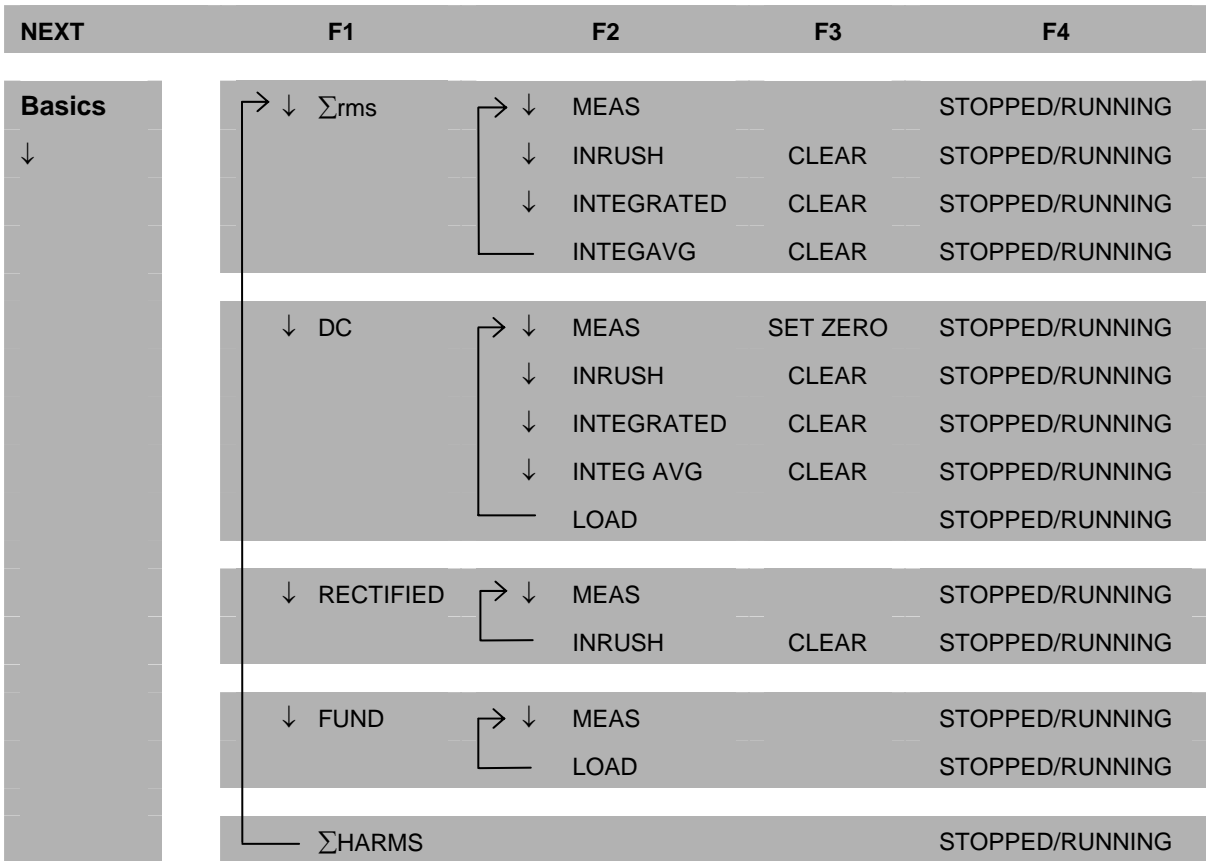

Figure 16. Sample Basics display screen

# Diagrams



**Note:** If you wish to display  $\Sigma_{HARMS}$ , RECTIFIED and FUND, press the button in the F2 position (second softkey from left) until MEAS comes up, then press F1 (first softkey on left).

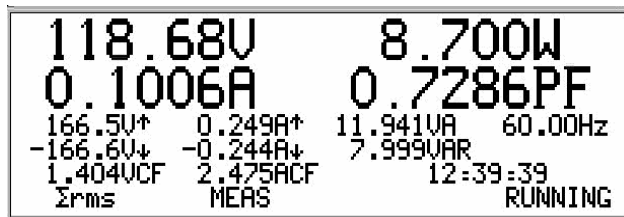

Figure 17. Basic  $\Sigma_{RMS}$  sample

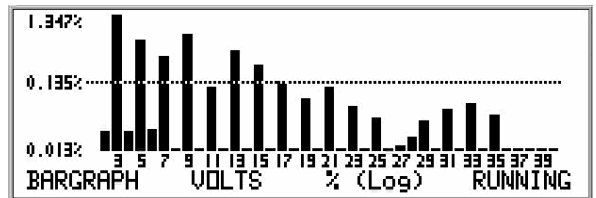
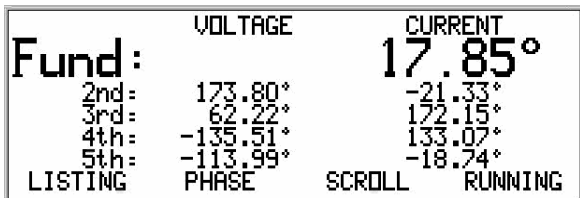
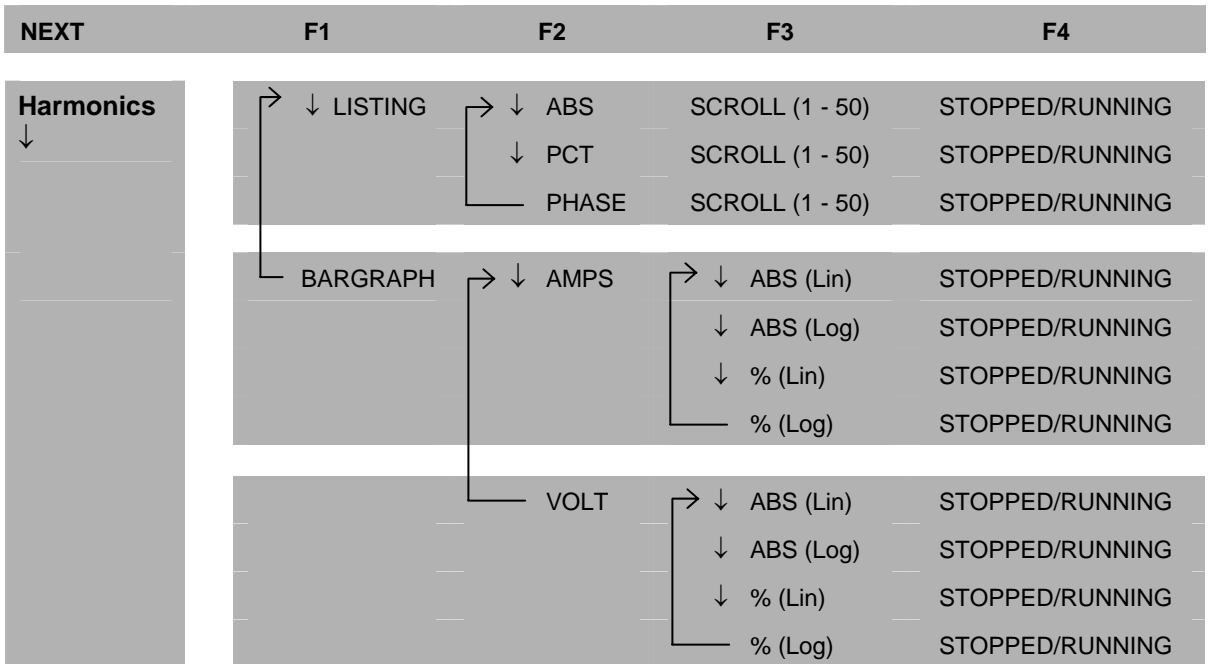

Figure 18. Harmonics Listing and Bargraph samples

NEXT	F1	F2	F3	F4
<b>Waveforms</b>	→ ↓ V&A CONT	ZOOMx0.5, x1, x2, x5		STOPPED/RUNNING
	↓ V&W CONT	ZOOMx0.5, x1, x2, x5		STOPPED/RUNNING
	↓ V&A DIST	ZOOMx0.5, x1, x2, x5		STOPPED/RUNNING
	↓ V PEAK	ZOOMx0.5, x1, x2, x5	CLEAR	STOPPED/RUNNING
	↓ A PEAK	ZOOMx0.5, x1, x2, x5	CLEAR	STOPPED/RUNNING
	↓ V GLITCH	ZOOMx0.5, x1, x2, x5	CLEAR	STOPPED/RUNNING
	— A GLITCH	ZOOMx0.5, x1, x2, x5	CLEAR	STOPPED/RUNNING

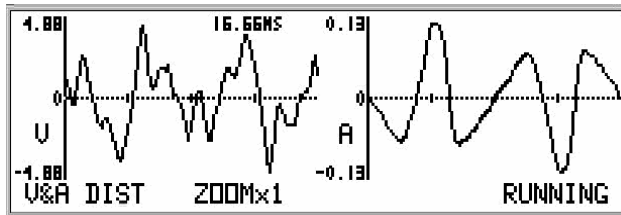

Figure 19. Waveforms V&A DIST sample



NEXT	F1	F2	F3	F4	
History	→ ↓ VOLTS	→ ↓ RMS ↓ PEAK ↓ ENVELOPE %THD	→ ↓ 0.4 sec/div	STOPPED/RUNNING	
			↓ 1 sec/div	STOPPED/RUNNING	
			↓ 2 sec/div	STOPPED/RUNNING	
			↓ 5 sec/div	STOPPED/RUNNING	
			↓ 10 sec/div	STOPPED/RUNNING	
		↓ AMPS	→ ↓ RMS ↓ PEAK ↓ ENVELOPE %THD	↓ 30 sec/div	STOPPED/RUNNING
			↓ 1 min/div	STOPPED/RUNNING	
			↓ 3 min/div	STOPPED/RUNNING	
			↓ 10 min/div	STOPPED/RUNNING	
			↓ 30 min/div	STOPPED/RUNNING	
	↓ WATTS		↓ 1 hr/div	STOPPED/RUNNING	
			↓ 3 hr/div	STOPPED/RUNNING	
	↓ VAR		↓ 6 hr/div	STOPPED/RUNNING	
			↓ 12 hr/div	STOPPED/RUNNING	
	PF		↓ 1 day/div	STOPPED/RUNNING	

**Note:** The time scale may be set while displaying any data.

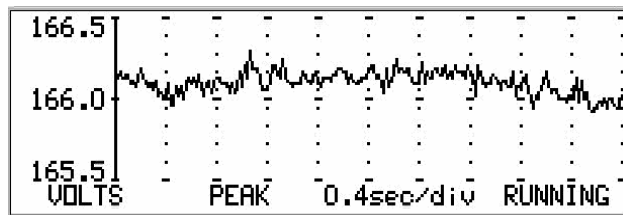

Figure 20. History VOLTS PEAK sample



---

# Viewing Results

Review this chapter to determine which display results best suit your test requirements.

## Display Screens

The screen displays shown here reflect the default options in the **Measurement Setup** screen. Refer to *Configuring the Power Analyzer*, page 20. For reference those defaults are—

- 20Hz—5KHz
- AC & DC
- 250ms
- Voltage

The default for DISPLAY CONTRAST is 8.

Note that if AC ONLY has been selected, then  $\Sigma$ rms will read: RMS (AC) and the message: NOT CONFIGURED FOR DC MEASUREMENT will display in the **Basics** DC screen.

If an input signal does not fit inside the configured range (**Measurement Setup**), then your analyzer may exhibit one of the following conditions—

- The screen may display a limited number of results
- A message may display on the screen instead of results
- You may not have access to some display screens

## Basics Group

The **Basics** group shows you a complete picture of the power results of your device. It has 14 different total display screens with up to 14 characteristics included in the screens.

### $\Sigma$ RMS

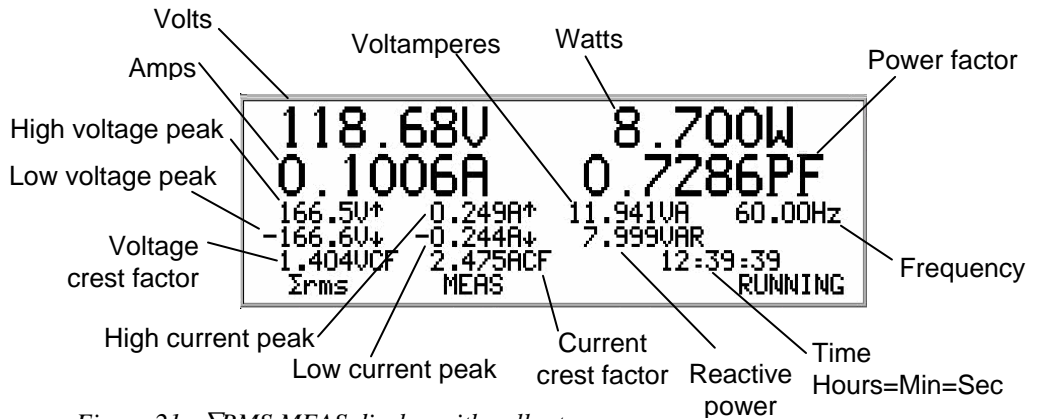

Figure 21.  $\Sigma$ RMS MEAS display with callouts



Figure 22.  $\Sigma$ RMS INRUSH display

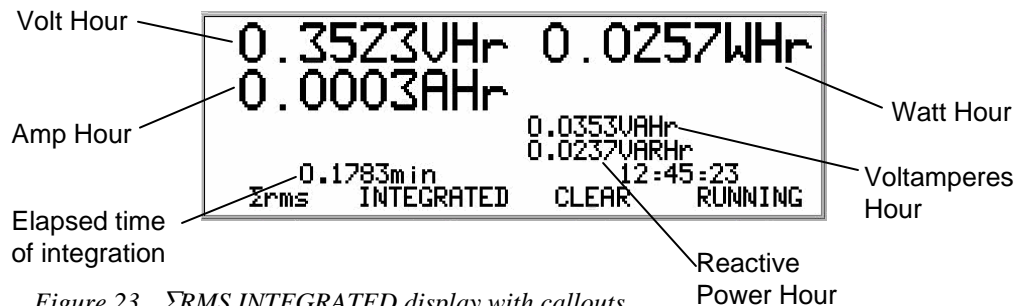

Figure 23.  $\Sigma$ RMS INTEGRATED display with callouts

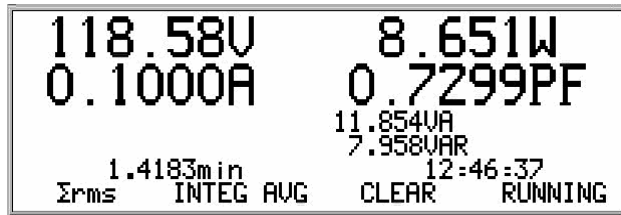

Figure 24.  $\Sigma$ RMS INTEG AVG display

## DC

Use the SET ZERO button to remove the DC offset from the internal Hall Effect transducers. Note that this function is unavailable if the measured current exceeds 160mArms (standard) or 800mArms (Option 40A) AC signal and DC signal.



Figure 25. Basics DC MEAS display



Figure 26. Basics DC INRUSH display

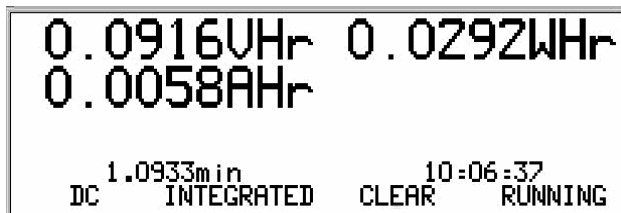

Figure 27. Basics DC INTEGRATED display



Figure 28. Basics DC INTEG AVG display

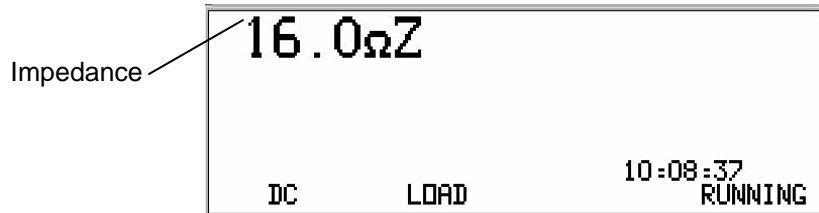

Figure 29. Basics DC LOAD display with callouts

## Rectified

If you wish to view the RECTIFIED displays, you must press the button in the F2 position until MEAS comes up, then press F1.

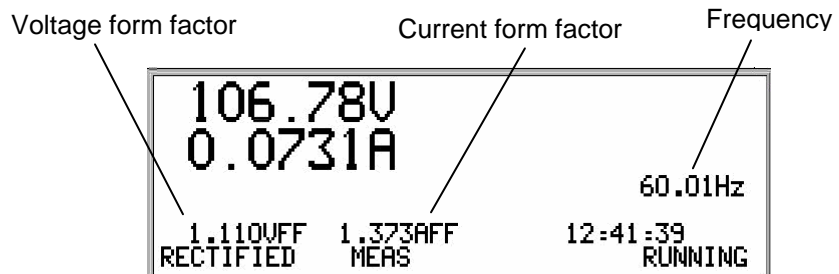

Figure 30. Basics RECTIFIED MEAS display with callouts



Figure 31. RECTIFIED INRUSH display

## Fund

If you wish to view the FUND displays, you must press the button in the F2 position until MEAS comes up, then press F1. Note that FUND LOAD is not shown.

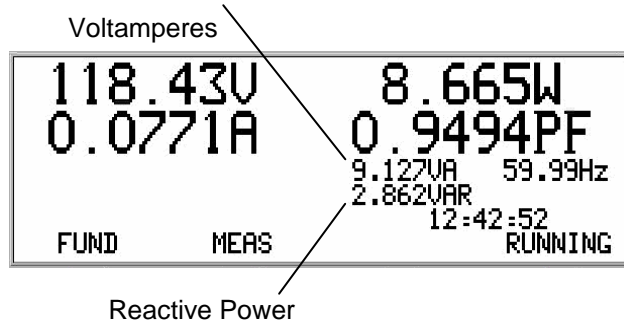

Figure 32. Basics FUND MEAS display with callouts

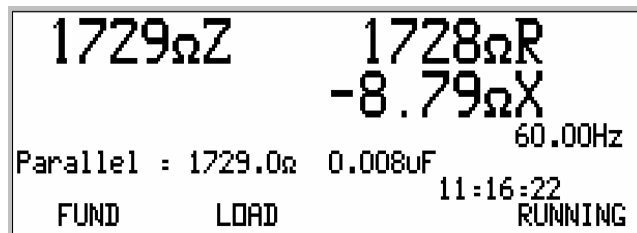

Figure 33. Basics FUND LOAD display

## ΣHARM

If you wish to view the ΣHARM display, you must press the button in the F2 position until MEAS comes up, then press F1.

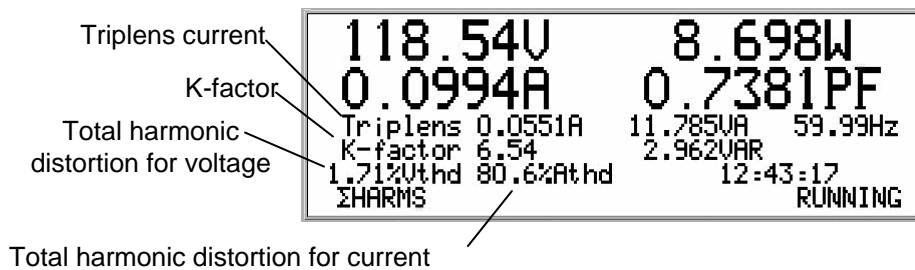

Figure 34. ΣHARMS display with callouts

## Harmonics Group

The **Harmonics** group of screens show harmonic results. These results can be viewed in a list or bargraph format. The list format shows the fundamental through to the 50<sup>th</sup> harmonic. The bargraph format shows through to the 40<sup>th</sup> harmonic.

### Listings

Each LISTING display screen is limited to a few lines. Use the SCROLL button to view the fundamental through the 50<sup>th</sup> harmonic result.

The listing screens show harmonics in—

- Absolute with THD
- Percentages with THD
- Phase (shift to voltage fundamental)

	VOLTAGE	CURRENT
<b>THD:</b>	<b>2.04V</b>	<b>0.063A</b>
Fund=	118.21V	0.0772A
2nd=	0.02V	0.0001A
3rd=	1.60V	0.0547A
4th=	0.02V	0.0001A
LISTING	ABS	SCROLL RUNNING

Figure 35. Harmonics LISTING ABS display

	VOLTAGE	CURRENT
<b>THD:</b>	<b>1.72%</b>	<b>80.92%</b>
Fund=	118.30V	0.0771A
2nd=	0.02%	0.16%
3rd=	1.33%	70.73%
4th=	0.03%	0.14%
LISTING	PCT	SCROLL RUNNING

Figure 36. Harmonics LISTING PCT display

	VOLTAGE	CURRENT
<b>Fund:</b>		<b>17.85°</b>
2nd=	173.80°	-21.33°
3rd=	62.22°	172.15°
4th=	-135.51°	133.07°
5th=	-113.99°	-18.74°
LISTING	PHASE	SCROLL RUNNING

Figure 37. Harmonics LISTING PHASE display



## Bargraphs

The bargraph displays show through the 40<sup>th</sup> harmonic for current and voltage in—

- Linear or logarithmically scaled percentage units
- Linear or logarithmically scaled absolute units

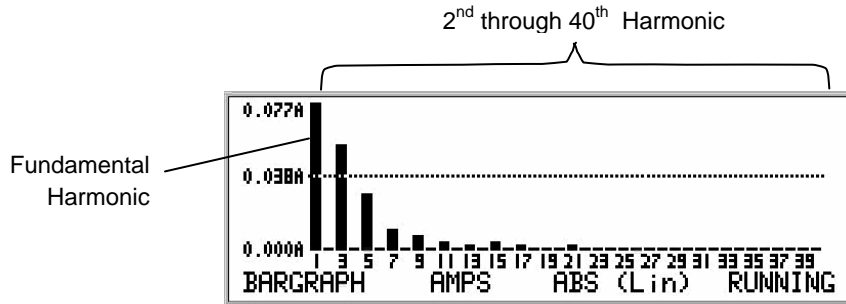

Figure 38. Harmonics AMPS ABS Lin display with callouts

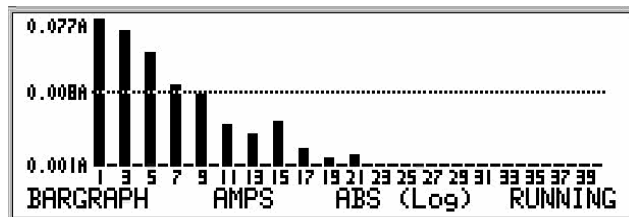

Figure 39. Harmonics AMPS ABS Log display

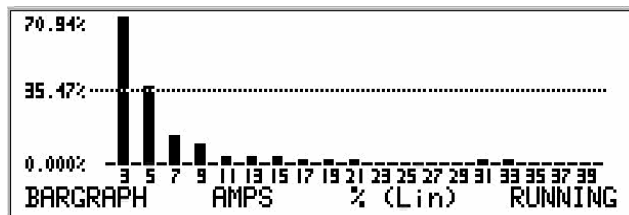

Figure 40. Harmonics AMPS % Lin display

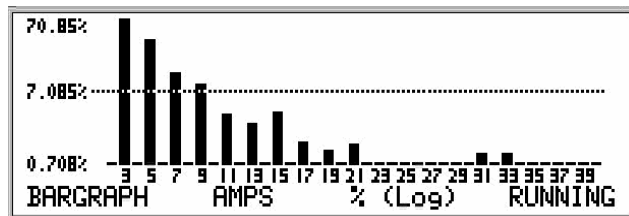

Figure 41. Harmonics AMPS % Log display

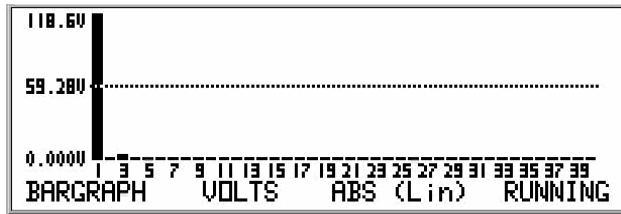

Figure 42. Harmonics VOLTS ABS Lin display

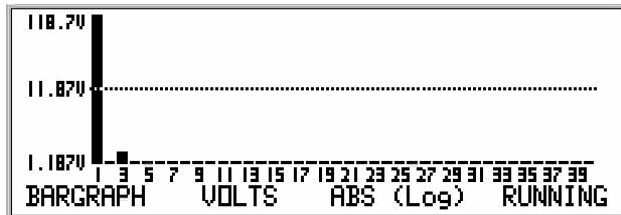

Figure 43. Harmonics VOLTS ABS Log display

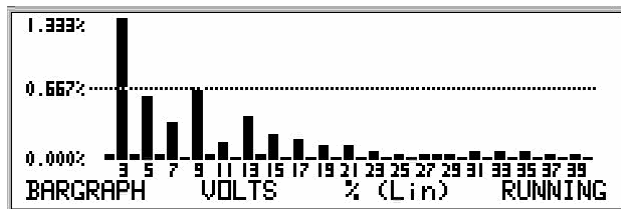

Figure 44. Harmonics VOLTS % Lin display

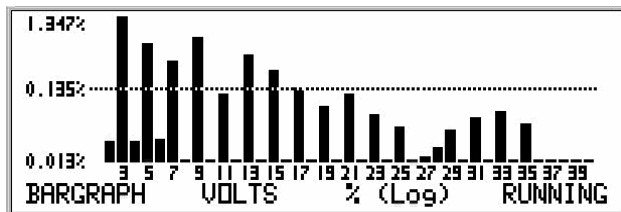

Figure 45. Harmonics VOLTS % Log display

# Waveforms Group

The **Waveforms** group shows continuous results for voltage, current and wattage. It also shows distortion, peak and glitches for voltage and current. The display screens are in xy waveform format. Numeric peak results are inset in the screens.

Each screen displays two waveforms for comparison purposes with additional information provided with an inset.

The waveforms can be viewed at zoom levels of x0.5, x1, x2, and x5. The analyzer will automatically center the input results vertically on the screen, no matter what range.

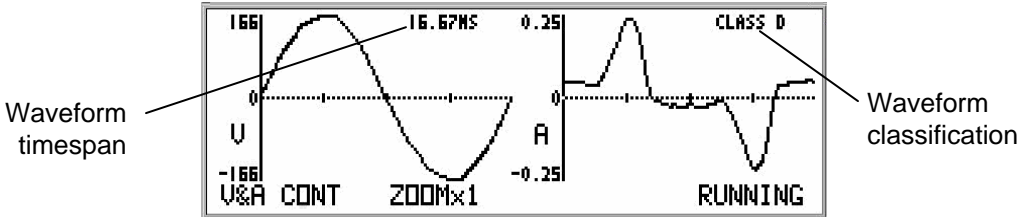

Figure 46. Waveforms V&A CONT display with callouts

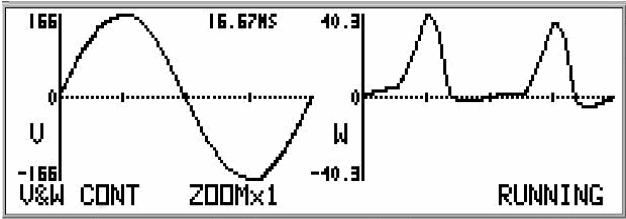

Figure 47. Waveforms V&W CONT display

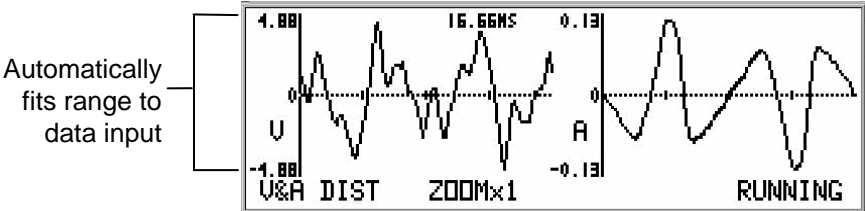

Figure 48. Waveforms V&A DIST display with callout

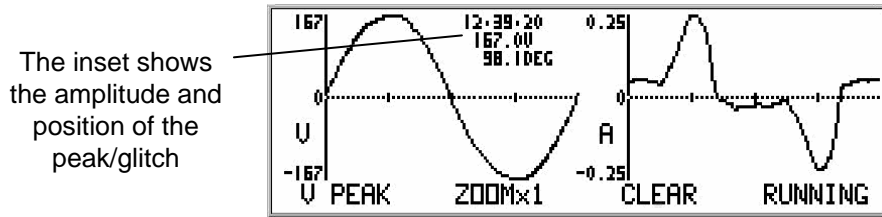

Figure 49. Waveforms V PEAK display with callout

V PEAK: V & A waveforms captured at the largest peak voltage.

**Note:** Use the CLEAR button to reset the display.

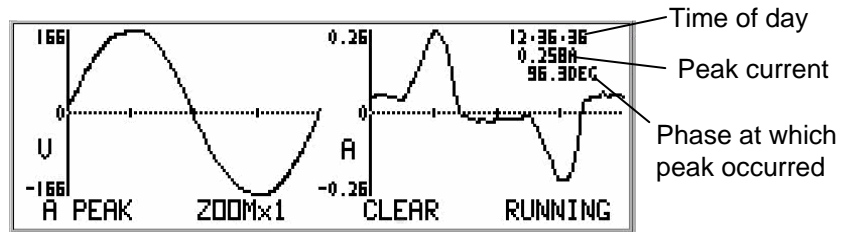

Figure 50. Waveforms A PEAK display with callouts

A PEAK: V & A waveforms captured at the largest peak current.

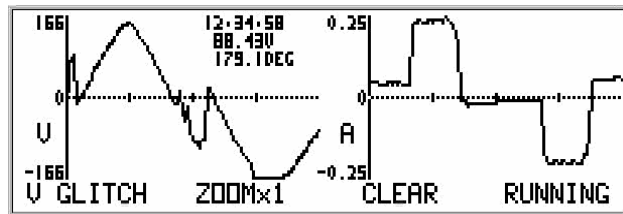

Figure 51. Waveforms V GLITCH display

V GLITCH: V & A waveforms captured at the largest voltage glitch.

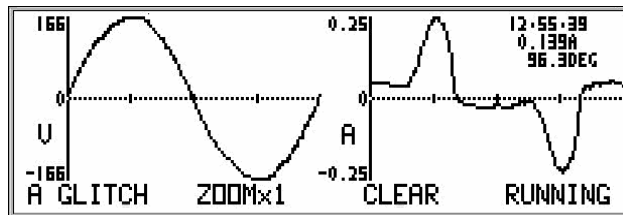

Figure 52. Waveforms A GLITCH display

A GLITCH: V & A waveforms captured at the largest current glitch.

## History Group

The **History** group gives you accumulated results at the following rates: 0.4 seconds, 1 second, 2 seconds, 5 seconds, 10 seconds, 30 seconds, 1 minute, 3 minutes, 10 minutes, 30 minutes, 1 hour, 3 hours, 6 hours, 12 hours, and one day per division.

The analyzer will automatically scale and center the input results vertically on the screen.

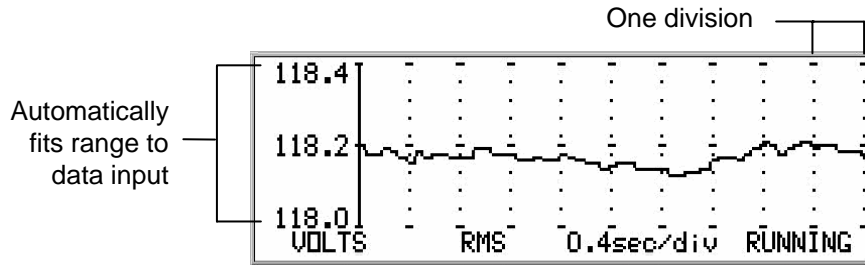

Figure 53. History VOLTS RMS display with callouts

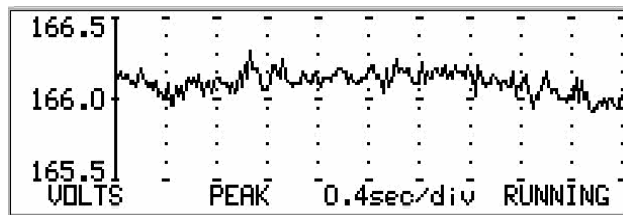

Figure 54. History VOLTS PEAK display

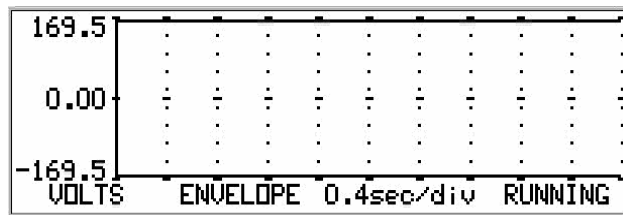

Figure 55. History VOLTS ENVELOPE display

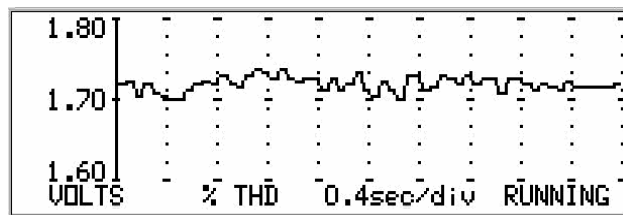

Figure 56. History VOLTS % THD display

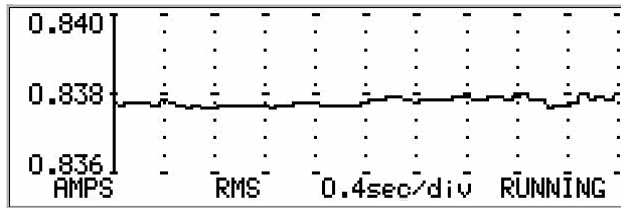

Figure 57. History AMPS RMS display

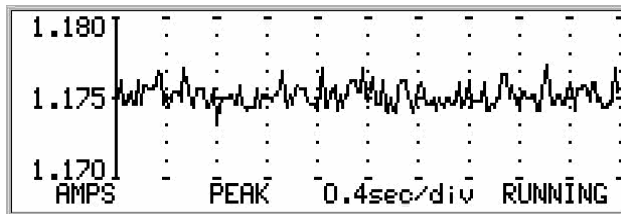

Figure 58. History AMPS PEAK display

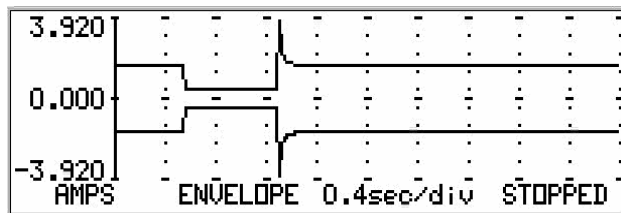

Figure 59. History AMPS ENVELOPE display

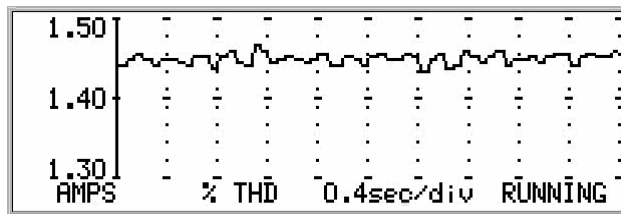

Figure 60. History AMPS % THD display

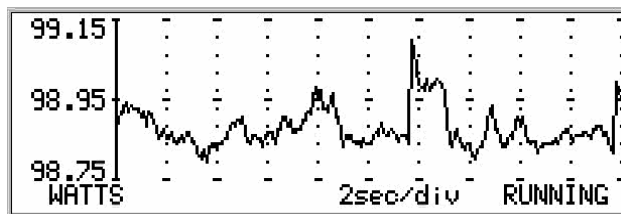

Figure 61. History WATTS display

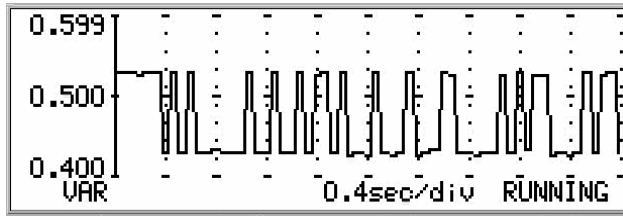

Figure 62. History VAR display

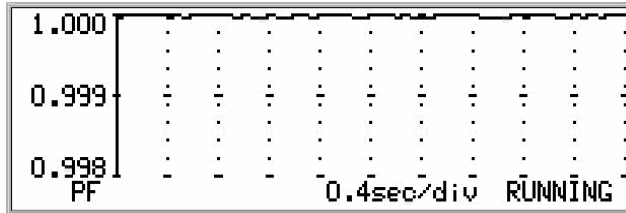

Figure 63. History PF display





---

# Printing Results

This chapter illustrates some of the various printouts available using the 2551/2551E. Each printout reflects the data from the display group you are presently viewing.

## Sample Printouts

To get the type of printout you want, check your setting in the **Interface Setup** screen. A text or graphic print is immediately initiated when the PRINT key is pressed for each of the results display screens.

Every printout includes—

- Descriptive title of the data
- Configuration selections
- Current date (month, day, year)
- Calibrated date
- Time in hours : minutes : seconds
- Elapsed time
- Xitron 2551 or Xitron 2551E
- Version number

**Note:** Select PCL2 within the **Interface Setup** screen for graphical printouts.

The samples provided have been printed from each of the display groups **Basics**, **Harmonics**, **Waveforms**, and **History**.

- All the data you view in the **Basics** group of displays will print on one page. See *Figure 64. Basic Measurement sample printout.*
- The **Harmonics** LISTING data including ABS, PCT, and PHASE will print on one page. See *Figure 65. Harmonics Data List sample printout.*

- The **Harmonics** BARGRAPH data will print separate barcharts for ABS, %, Lin or Log for current or voltage. See *Figure 66. Current Harmonics Barchart* and *Figure 67. Current Harmonics Barchart sample printout*.
- For the **Waveforms** group, volts, amps and power waveforms will print together if a graphical print is selected. See *Figure 68. Volts, Amps, Power Waveforms sample printout*. If a text only printer is selected, then volts and amps will print together. See *Figure 69. Volts and Amps Waveforms nongraphic sample printout*.
- Voltage and current **Waveforms** for PEAK, DIST and GLITCH captures will print separately. See *Figure 70. Volts Glitch Capture sample printout*, *Figure 71. Amps Peak Capture sample printout* and *Figure 72. Distortion Waveforms sample printout*.
- Each **History** display will print a full page of graphically formatted data. See *Figure 73. Voltage Level History sample printout* and *Figure 74. Voltage Level History nongraphic sample printout*.

The following pages illustrate the sample printouts—

To print the following, press the PRINT button from any one of the **Basics** group of display screens:  $\Sigma$ rms, DC, RECTIFIED, FUND, or  $\Sigma$ HARMS.

		BASIC MEASUREMENTS			
Xitron 2551 v2.6		Jan 12 2006, 09:51:40			
		MEASURED	INRUSH	INTEGRATED TOTAL	FOR 0.0000Hr AVERAGE
FREQUENCY	:	59.99Hz			
VOLTAGE	RMS :	116.64V	116.70V	0.0000VHr	0.00V
	Fundamental :	116.62V			
	Harmonic :	116.64V			
	DC :	0.02V	-4.12V	0.0000VHr	0.00V
	Rectified :	105.78V	105.83V		
	+Peak :	162.66V	162.89V		
	-Peak :	-162.56V	-162.66V		
	Crest Factor :	1.394			
	Form Factor :	1.103			
	THD :	2.20%			
CURRENT	RMS :	0.172A	0.173A	0.0000AHr	0.000A
	Fundamental :	0.096A			
	Harmonic :	0.166A			
	Triplens :	0.096A			
	Odd Triplens :	0.096A			
	DC :	0.044A	0.046A	0.0000AHr	0.000A
	Rectified :	0.104A	0.105A		
	+Peak :	0.566A	0.586A		
	-Peak :	-0.482A	-0.494A		
	Crest Factor :	3.299			
Form Factor :	1.652				
THD :	140.85%				
WATTS	Total :	10.98W	11.07W	0.0000WHr	0.00W
	Fundamental :	11.14W			
	Harmonic :	10.99W			
	DC :	0.00W	-0.19W	0.0000WHr	0.00W
VAR	Total :	15.91VAR	16.01VAR	0.0000VARHr	0.00VAR
	Fundamental :	0.98VAR			
	Harmonic :	0.99VAR			
VA	Total :	20.01VA		0.0000VAHr	0.00VA
	Fundamental :	11.18VA			
	Harmonic :	19.32VA			
	DC :	0.00VA	-0.19VA	0.0000VAHr	0.00VA
POWER FACTOR	Total :	0.5486			0.0000
	Fundamental :	0.9961			
	Harmonic :	0.5690			
LOAD	K-Factor :	22.07			
	Fundamental :	1216.2ohms ( 1213.6-106.62j)			
		1218.8ohms    0.1912uF			
Bandwidth = 20Hz- 5KHz AC & DC 50 harmonics Sync = Voltage					
Results averaged over 250ms					
Current Input = Internal +0001.00A:01.0000A					
Calibrated on Jan 03 2006					

Figure 64. Basic Measurement sample printout

To print the following, press the PRINT button from any one of the **Harmonics LISTING** display screens: PCT, ABS, or PHASE.

Xitron 2551 v2.6		HARMONICS DATA LIST		
		Jan 12 2006, 09:52:41		
	VOLTAGE		CURRENT	
THD :	2.57V	2.21%	0.135A	141.21%
Fund:	116.55V	0.00deg	0.096A	5.14deg
2nd:	0.02V	0.02%	0.000A	0.21%
3rd:	1.85V	1.58%	0.088A	91.76%
4th:	0.01V	0.01%	0.000A	0.47%
5th:	1.21V	1.03%	0.074A	77.00%
6th:	0.00V	0.00%	0.000A	0.37%
7th:	1.23V	1.06%	0.056A	58.84%
8th:	0.00V	0.00%	0.000A	0.21%
9th:	0.40V	0.34%	0.037A	38.34%
10th:	0.00V	0.00%	0.000A	0.16%
11th:	0.11V	0.10%	0.019A	20.19%
12th:	0.00V	0.00%	0.000A	0.21%
13th:	0.12V	0.10%	0.006A	6.05%
14th:	0.00V	0.00%	0.000A	0.26%
15th:	0.13V	0.11%	0.004A	4.59%
16th:	0.01V	0.01%	0.000A	0.21%
17th:	0.11V	0.09%	0.008A	8.29%
18th:	0.00V	0.00%	0.000A	0.21%
19th:	0.10V	0.08%	0.008A	8.03%
20th:	0.00V	0.00%	0.000A	0.42%
21st:	0.06V	0.06%	0.005A	5.27%
22nd:	0.01V	0.01%	0.000A	0.16%
23rd:	0.02V	0.02%	0.002A	1.72%
24th:	0.03V	0.02%	0.000A	0.21%
25th:	0.01V	0.01%	0.001A	1.36%
26th:	0.02V	0.01%	0.000A	0.47%
27th:	0.03V	0.03%	0.003A	3.23%
28th:	0.04V	0.03%	0.000A	0.16%
29th:	0.03V	0.02%	0.003A	3.44%
30th:	0.02V	0.01%	0.000A	0.21%
31st:	0.02V	0.01%	0.002A	2.35%
32nd:	0.01V	0.01%	0.000A	0.16%
33rd:	0.03V	0.03%	0.001A	0.83%
34th:	0.01V	0.01%	0.000A	0.10%
35th:	0.04V	0.03%	0.001A	0.63%
36th:	0.00V	0.00%	0.000A	0.16%
37th:	0.01V	0.01%	0.001A	1.46%
38th:	0.00V	0.00%	0.000A	0.26%
39th:	0.03V	0.02%	0.002A	1.67%
40th:	0.01V	0.00%	0.000A	0.47%
41st:	0.03V	0.02%	0.001A	1.10%
42nd:	0.00V	0.00%	0.000A	0.16%
43rd:	0.02V	0.02%	0.001A	0.52%
44th:	0.00V	0.00%	0.000A	0.10%
45th:	0.01V	0.01%	0.001A	0.68%
46th:	0.00V	0.00%	0.000A	0.26%
47th:	0.02V	0.02%	0.001A	1.04%
48th:	0.00V	0.00%	0.000A	0.26%
49th:	0.03V	0.03%	0.001A	1.20%
50th:	0.00V	0.00%	0.000A	0.16%

Bandwidth = 20Hz- 5KHz AC & DC 50 harmonics Sync = Voltage  
 Results averaged over 250ms  
 Current Input = Internal +0001.00A:01.0000A  
 Calibrated on Jan 03 2006

Figure 65. Harmonics Data List sample printout

To print the following, press the PRINT button from **Harmonics BARGRAPH AMPS %** (Lin) display screen. Print using the default setting for a PCL2 printer.

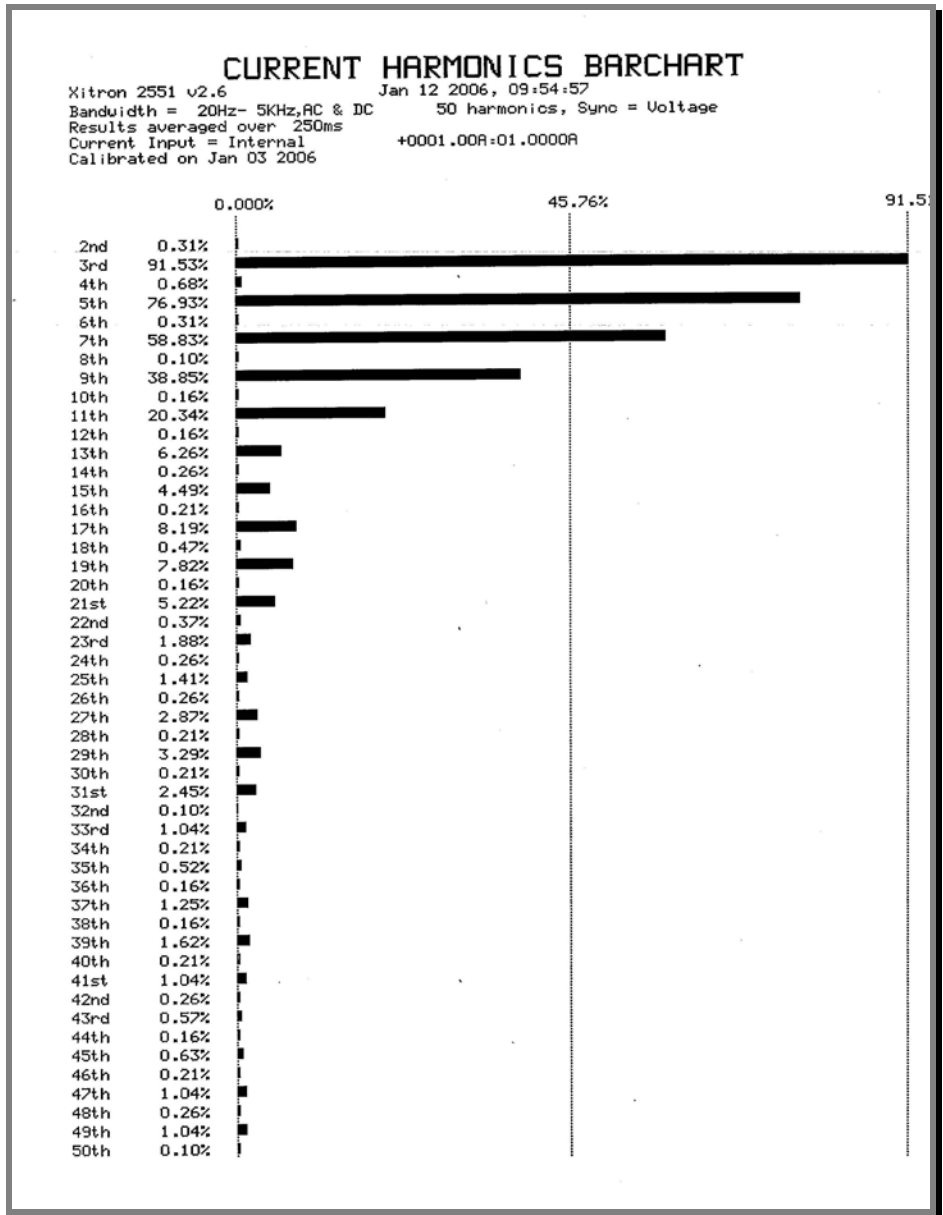

Figure 66. Current Harmonics Barchart sample printout

To print the following, press the PRINT button from **Harmonics BARGRAPH VOLTS % (Log)** display screen.

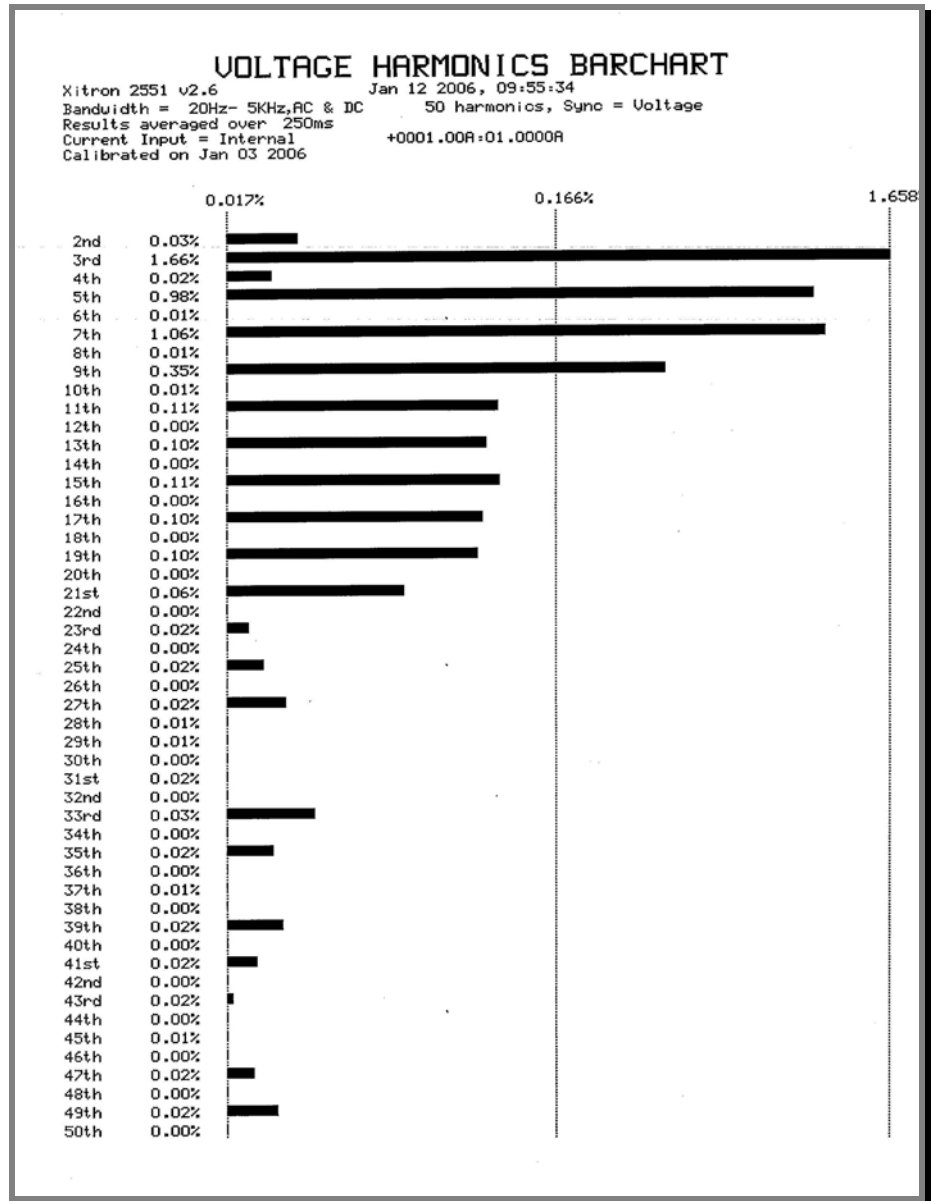

Figure 67. Current Harmonics Barchart sample printout

To print the following, press the PRINT button from **Waveforms** V&A CONT or V&W CONT display screens. Print using the default setting for a PCL2 printer.

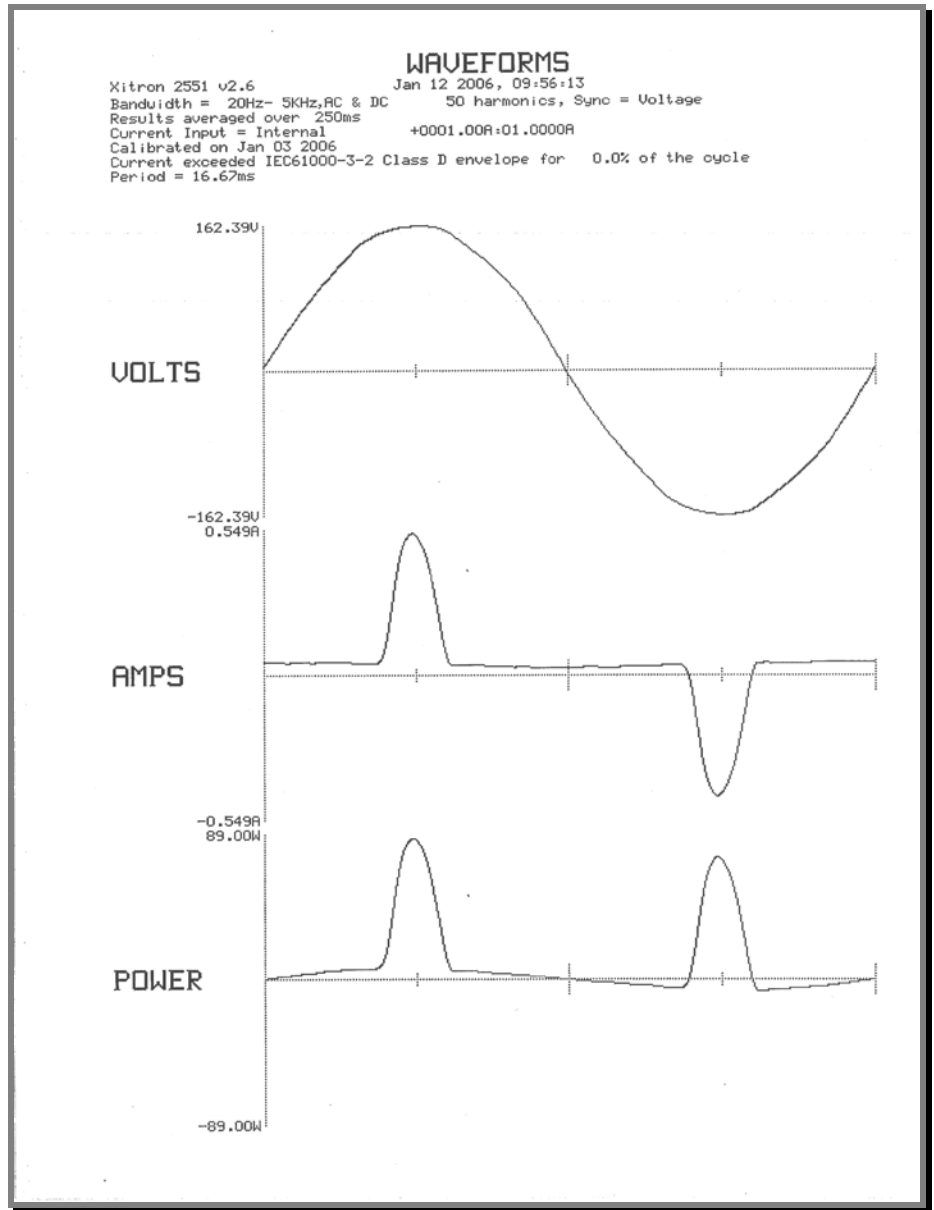

Figure 68. Volts, Amps, Power Waveforms sample printout

To print the following, press the PRINT button from the **Waveforms V&A CONT** display screen. This sample printed with the Analyzer configured for Text printer.

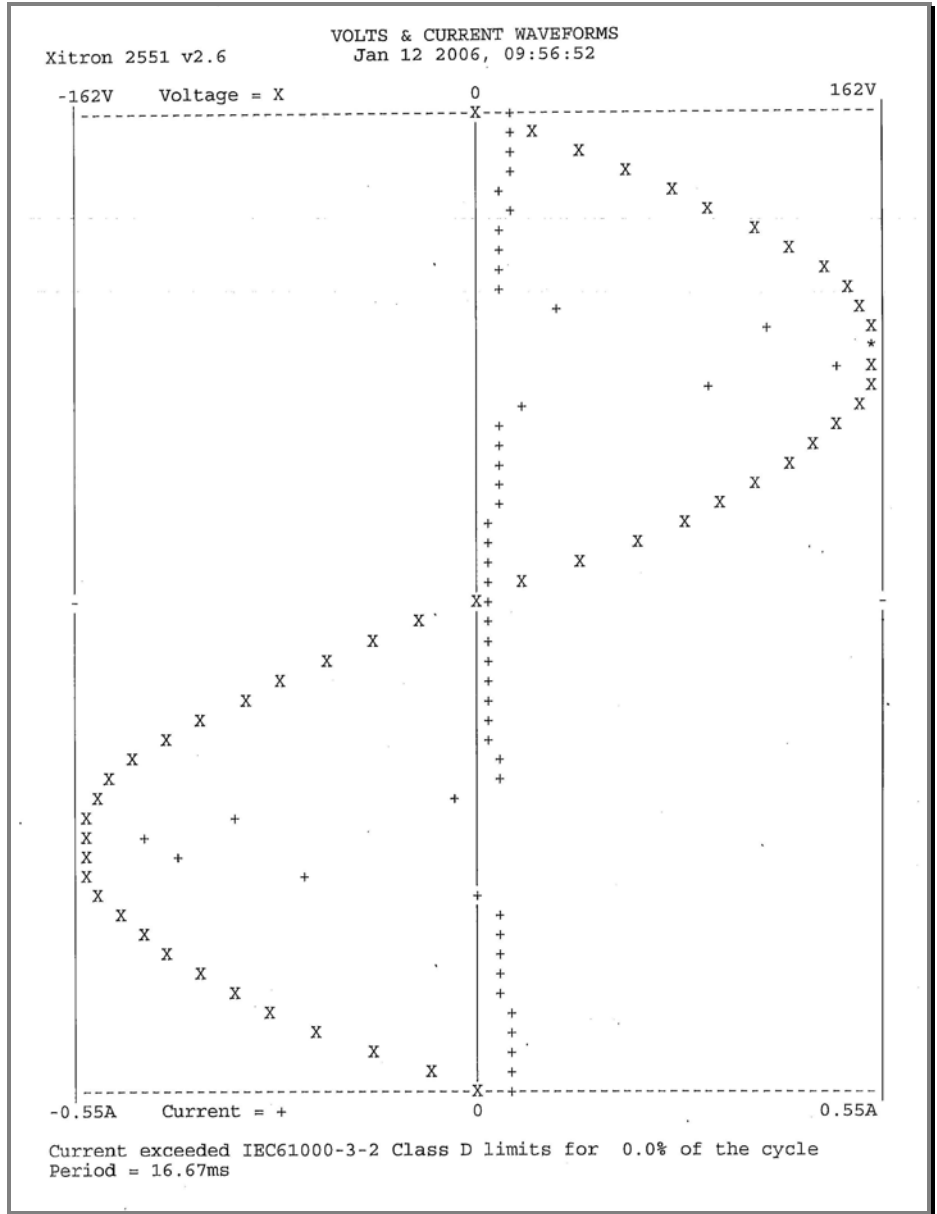

Figure 69. Volts and Amps Waveforms nongraphic sample printout



To print the following, press the PRINT button from the **Waveforms VGLITCH** display screen. Print using the default setting for a PCL2 printer.

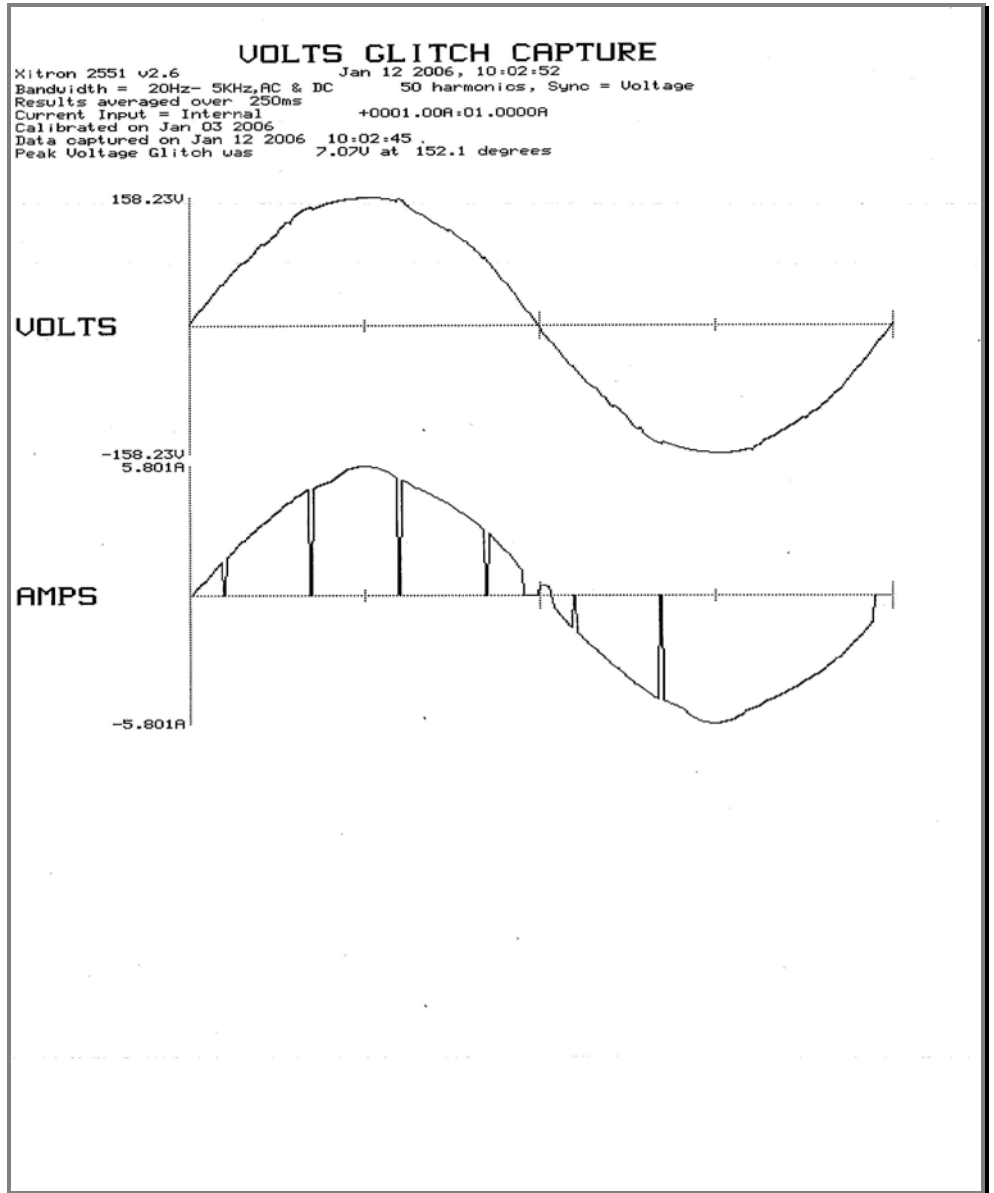

Figure 70. Volts Glitch Capture sample printout

To print the following, press the PRINT button from the **Waveforms APEAK** display screen. Print using the default setting for a PCL2 printer.

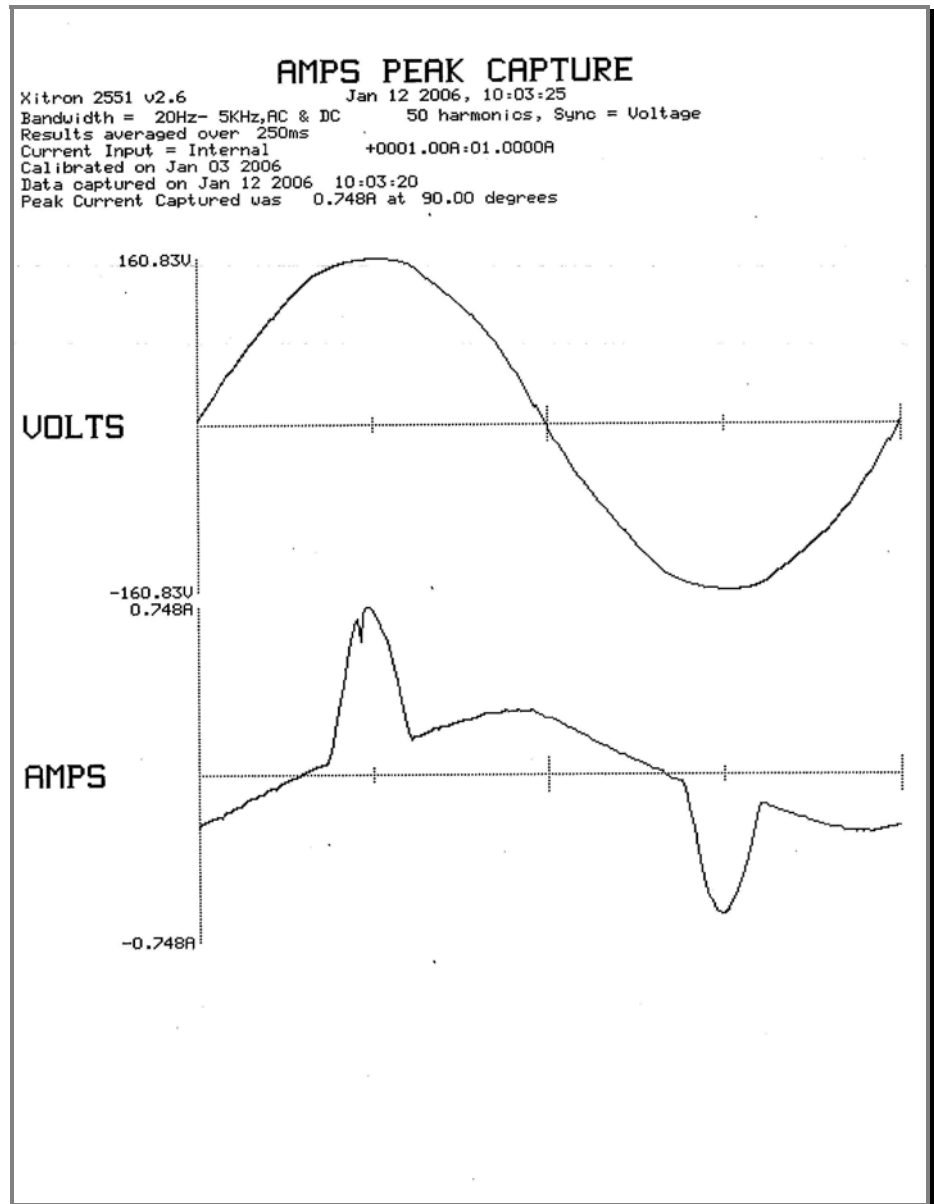

Figure 71. Amps Peak Capture sample printout

To print the following, press the PRINT button from the **Waveforms V&A DIST** display screen. Print using the default setting for a PCL2 printer.

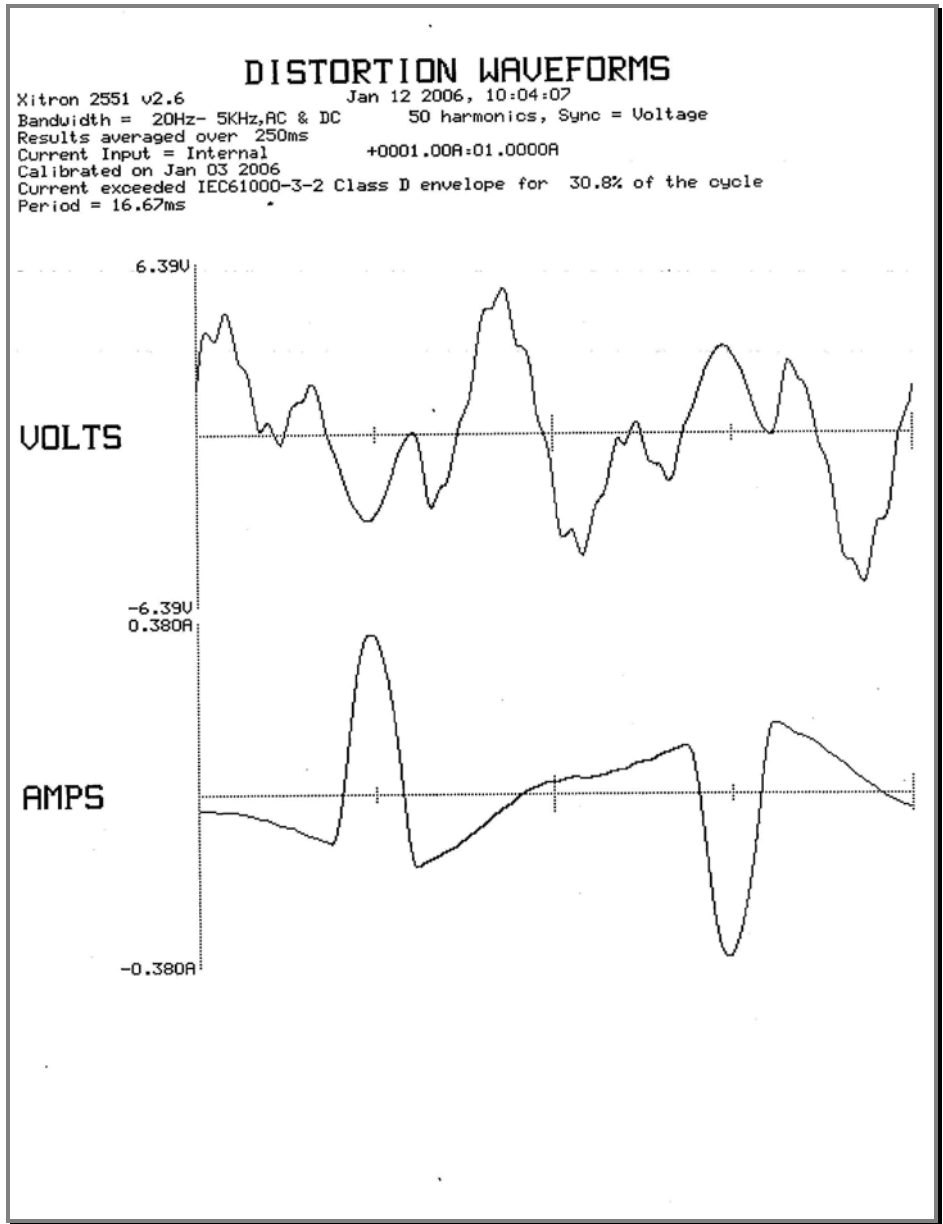

Figure 72. Distortion Waveforms sample printout

To print the following, press the PRINT button from any one of the **History VOLTS** display screens: RMS, PEAK, ENVELOPE, %THD. Print using the default setting for a PCL2 printer.

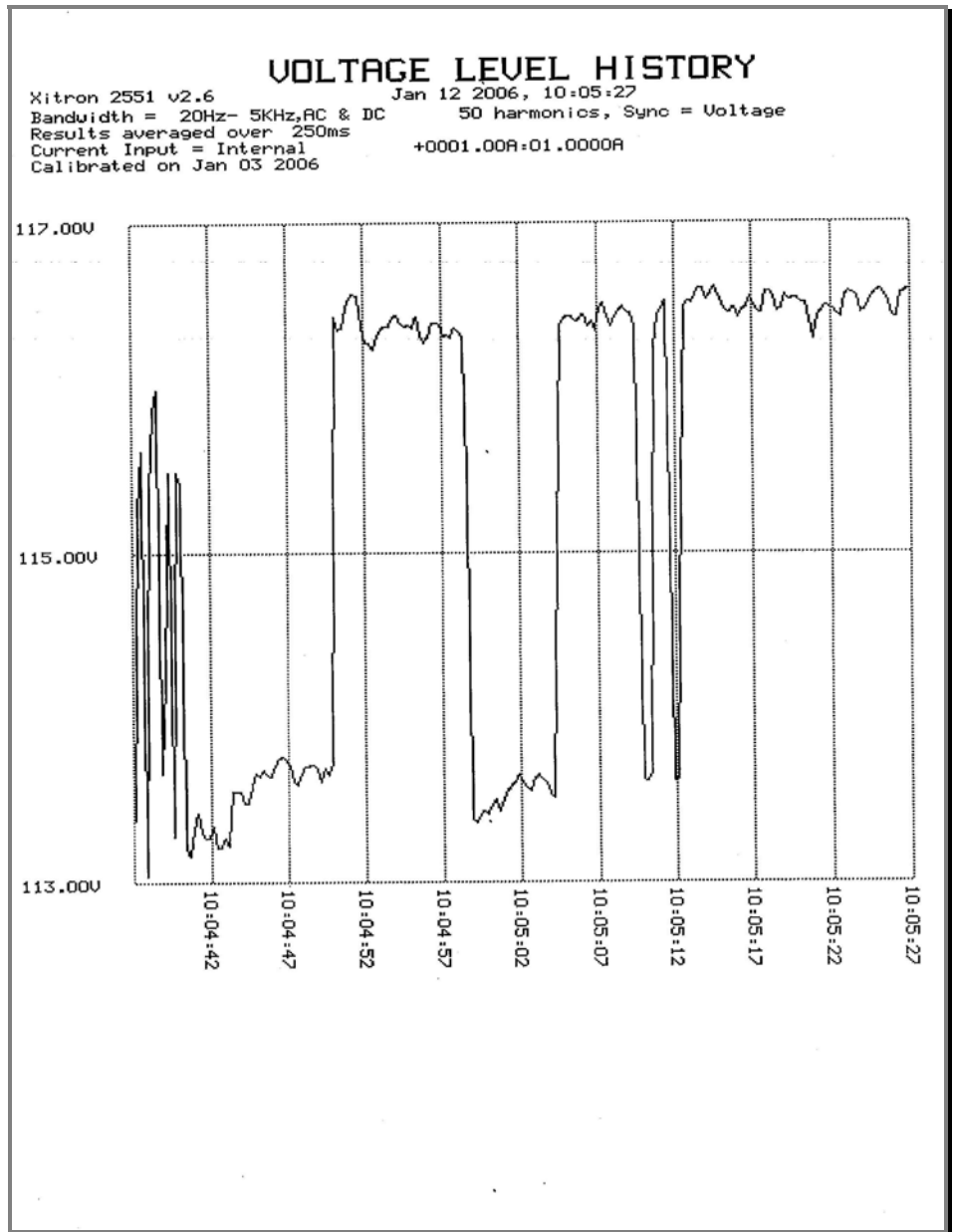

Figure 73. Voltage Level History sample printout

To print the following, press the PRINT button from any one of the **History** VOLTS display screens: RMS, PEAK, ENVELOPE, or %THD. This sample printed with the analyzer configured for Text printer.

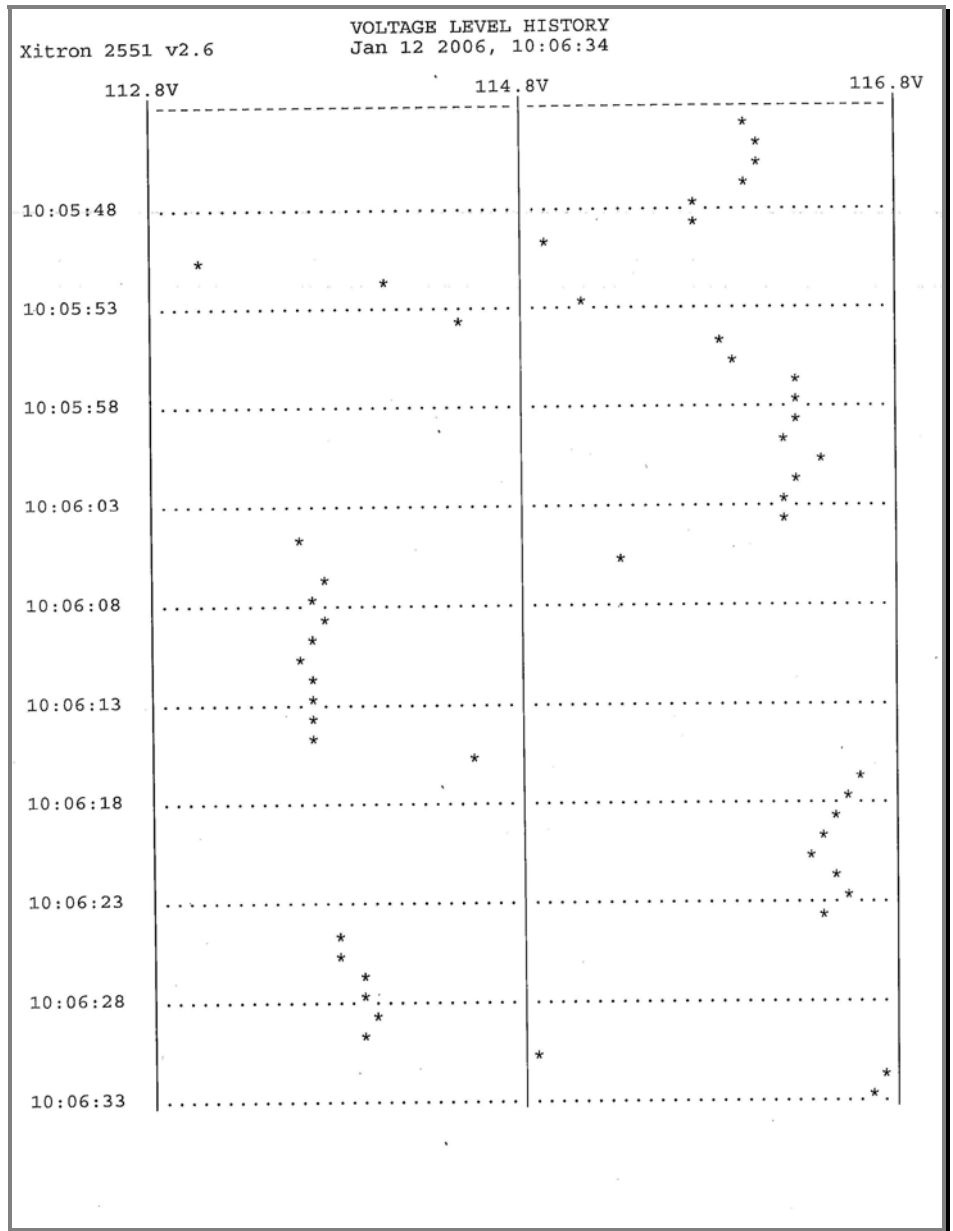

Figure 74. Voltage Level History nongraphic sample printout



# Calibration

This chapter describes how to remove DC current offset and how to calibrate both the 2551 and 2551E. The calibration signal levels given are for 950V, 8A options. Other options will require different levels for calibration. Please refer to the **Product Options Fitted** screen accessible from the **Setup Index** to ensure you are applying the correct levels for your Analyzer.

## Removing DC Current Offsets

It is recommended that this procedure be performed at regular intervals or whenever large ambient temperature changes occur  $> 5^{\circ}\text{C}$  from TCAL ( $23^{\circ}\text{C}$ ). If option E is fitted, then perform this procedure when changing the external current transducer. Note that the DC Current Offset procedure must be applied to all of the CURRENT INPUT SELECTIONS fitted in the 2551E (Internal, External Amps and External Volts).

◆ *To remove DC Current Offsets—*

1. From the **Setup Index** display, press the CURSOR button twice to highlight CURRENT INPUT.

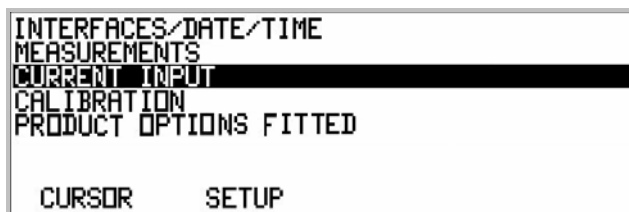

Figure 75. . Setup Index screen with Current Inputs selected

2. Press the SETUP button. The presently selected INPUT SELECTION will be highlighted. Refer to the illustration below.



Figure 76. INPUT SELECTION selected

3. Press the CHANGE button to select another INPUT SELECTION, as required.
  - For 2551E: Internal, External Amps and External Volts
  - For 2551: Internal
4. Press the DONE button.
5. Press the CURSOR button three times, the CALIBRATION choice is now highlighted.

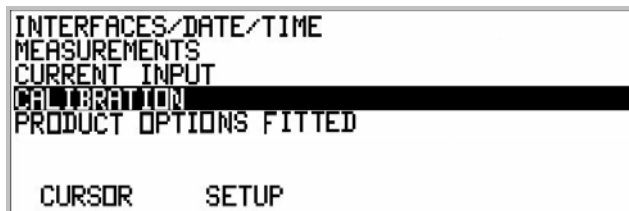

Figure 77. CALIBRATION selected

6. Press the SETUP button. The display changes to the **Calibration Setup** as shown below.



Figure 78. DC ZERO Date selected

7. Ensure that there is no current flow in the selected current input (the voltages need not be removed).



8. Press the PERFORM key. Any DC offset in the current measurement is measured and subtracted from all future measurements. The date displayed next to DC ZERO changes to today's date. Offsets are separately stored for each of the current input selections. Offsets up to 10% of the full-scale value for the respective current input can be accommodated.
9. Press the DONE key to return to the main **Setup Index** screen.

## Calibrating the Power Analyzer

The analyzer is fully specified for one year of operation. Recommended maintenance includes an annual calibration and if Option E is fitted, calibrate when changing the external current transducer. A full calibration includes three calibration (cal) points: open circuit, voltage and current. Note that external calibration of the power analyzer must be performed for all (three) of the CURRENT INPUT SELECTIONS fitted in the 2551E.

You can access all three cal points from the **Setup Index** display:

- The voltage cal point requires a calibrator that can drive a 2mA load at a minimum 0.025% accuracy and 0.01% short-term stability.
- The current cal point requires a calibrator that can drive a 200mV burden at a minimum 0.025% accuracy and 0.01% short-term stability.
- Use a Fluke 5700 multi-function calibrator or equivalent for calibrating the standard 2551. Use a Fluke 5725A or equivalent to calibrate the power analyzer 40A Option.

## Calibration Procedures

The user may calibrate the External Current Inputs with a user supplied current transducer connected, however the user should note that all calibrations are carried out at DC thus an inductive type transducer cannot be used during calibration. If a transducer is to be used, then for best results, use the nominal current transducer-scaling ratio. If the power analyzer's external current inputs are to be calibrated without an external transducer fitted, then the scale factor should be set to +1.0:1.0.

If Option E is fitted, then each of the Current Inputs (Internal, External Amps and External Volts) should be selected individually and the calibration procedure performed. The date shown as the last calibration date is the date that the presently selected current input was successfully calibrated.

Select the next appropriate INPUT SELECTION from the **Current Inputs** screen as described in *Removing DC Current Offsets* page 63.

**Note:** For a quick reference when calibrating refer to the *Calibration Connection Table* on page 72.

- ◆ **To change the CURRENT INPUT selection—**
  - Press the NEXT button until you see the main **Setup Index** display. If Option E is fitted, then highlight CURRENT INPUT and follow the selection procedure as shown in *Removing DC Current Offsets* on page 63.
- ◆ **To access the Calibration Setup display—**
  1. Return to the main **Setup Index** display using the NEXT button.
  2. Press the CURSOR button three times, the CALIBRATION choice is now highlighted, as shown.

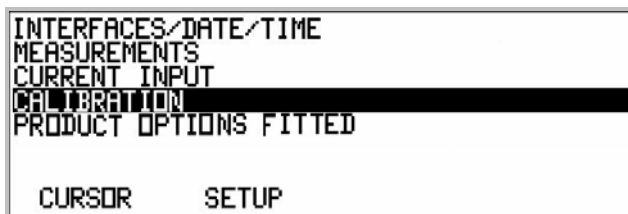

Figure 79. Calibration selected

3. Press the SETUP button. The display changes to the **Calibration Setup** display.
4. Press the CURSOR key, once. The date that the power analyzer was last calibrated is now highlighted.

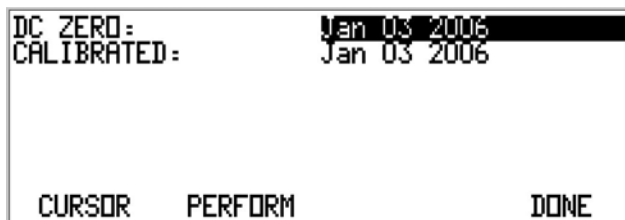

Figure 80. Calibration Date selected

- ◆ **To perform the open circuit point cal—**
  1. Press PERFORM. The display will show: INPUT = ALL INPUTS OPEN CIRCUIT prompt.

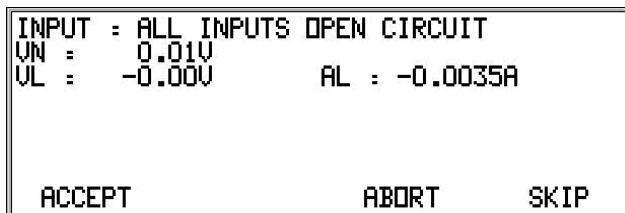

Figure 81. Open Circuit Point prompt

2. Ensure that all wires from the source and load connectors on the back of the analyzer have been removed.

**Note:** ESD and EMI noise can prevent registering zero values for open circuit calibration.

3. Press ACCEPT.
4. Wait one minute until the readings settle. The values for VN, VL and AL should zero out.
5. Press ACCEPT again and wait until the readings settle to within  $\pm 0.1$ .
6. Press NEXT when readings are within specification.

If you choose *not* to perform the next cal point, press SKIP instead of NEXT.

**Note:** If you skip any of the three cal points, the calibration date in the **Setup Index** screen will not be updated.

## Voltage Calibration

Depending on voltage option, the voltage cal point prompt will display—

INPUT = 400VDC SOURCE L (A) & N TO CHASSIS

INPUT = 200VDC SOURCE L (A) & N TO CHASSIS

INPUT = 120VDC SOURCE L (A) & N TO CHASSIS

```

INPUT : 200VDC SOURCE L & N TO CHASSIS
VN : -100.00%
VL : -100.00%          AL :

WARNING! READING(S) OUTSIDE OF TOLERANCE
          GO BACK      ABORT      SKIP
  
```

Figure 82. Voltage Point Initial display



**WARNING: SHOCK HAZARD. LETHAL VOLTAGES OR CURRENT MAY BE PRESENT. ENSURE NO VOLTAGE OR CURRENT EXISTS ON THESE CONNECTIONS PRIOR TO ATTEMPTING TO CONNECT TO THESE INPUT TERMINALS.**

◆ **To perform the internal voltage point cal—**

1. Connect the negative lead of the calibrator to CHASSIS GROUND binding post.
2. Connect the positive lead of the calibrator to SOURCE N and L (A) binding posts on the rear panel.

3. Apply the proper voltage input as shown on the display.

```

1.000ADC TO EXTERNAL TRANSDUCER A
1.000VDC TO BNC INPUT A
VN =                               AL : -100.20%
VL =

WARNING! READING(S) OUTSIDE OF TOLERANCE
          GO BACK   ABORT   SKIP

```

Figure 83. External Voltage Point display

4. Wait one minute for the VN, VL and AL readings to settle and press ACCEPT.
5. Wait another minute for the readings to settle to  $0 \pm 0.1$  and press ACCEPT.
6. Press NEXT when the readings are within specification.
7. Press SAVE DATA when all readings remain within specification.



◆ **To perform the external voltage point cal—**

1. Connect the negative lead of the calibrator to the Coax Shield.
2. Connect the positive lead of the calibrator to EXTERNAL INPUT (BNC), which is the center conductor of Coax on the rear panel.
3. Apply the proper voltage input as shown on display.

```

INPUT : 200VDC SOURCE L & N TO CHASSIS
VN = 0.000%
VL = -0.000%           AL :

READINGS USING UPDATED CALIBRATION DATA
ACCEPT   GO BACK   ABORT   NEXT

```

Figure 84. Voltage Point Zero Readings

4. Wait one minute for the readings to settle and press ACCEPT.
5. Wait another minute for the readings to settle to within  $0 \pm 0.1$  and press ACCEPT.
6. Press NEXT when the readings are within specification.
7. Press SAVE DATA when readings remain within specification.

If you choose *not* to perform the next cal point, press SKIP instead of NEXT.

**Note:** If you skip any calibration points, the calibration date on the **Setup** display will not be updated.

## Current Calibration

The current cal point display will show one of the following prompts—

INPUT = 2ADC SOURCE L (A) TO LOAD L (A) 8A version

INPUT = 10ADC SOURCE L (A) TO LOAD L (A) 40A version

**Note:** The current level shown on the display depends upon which current input option is fitted.

```

INPUT : 2ADC SOURCE L TO LOAD L
UN :
UL : AL : -99.99%

WARNING! READING(S) OUTSIDE OF TOLERANCE
          GO BACK ABORT SKIP
  
```

Figure 85. Internal Current Cal Point display



**WARNING: SHOCK HAZARD. LETHAL VOLTAGES OR CURRENT MAY BE PRESENT. ENSURE NO VOLTAGE OR CURRENT EXISTS ON THESE CONNECTIONS PRIOR TO ATTEMPTING TO CONNECT TO THESE INPUT TERMINALS.**

◆ **To perform the internal current cal point—**

1. Connect the negative lead of the calibrator to the LOAD L (A) receptacle.
2. Connect the positive lead of the calibrator to the SOURCE L (A) receptacle.
3. Apply the proper current input as shown on the display.

```

10ADC SOURCE A(+) TO LOAD A(-)
UN :
UL : AL : -100.00%

WARNING! READING(S) OUTSIDE OF TOLERANCE
          GO BACK ABORT SKIP
  
```

Figure 86. Load L (A) Current Cal Point display

4. Wait one minute for the readings to settle and press ACCEPT.
5. Wait one minute for the readings to settle to  $0 \pm 0.1$  and press ACCEPT.

*Press NEXT when the readings are within specification.*

6. Press SAVE DATA when readings remain within specification.
7. Press DONE when this step is complete.



◆ *To perform the external current cal point—*

1. Connect calibrator lead delivering current to the LOAD L (A) receptacle.
2. Connect the voltage lead of the calibrator to EXTERNAL INPUT (BNC).
3. Apply the proper current input as shown on the display.

```

1.000ADC TO EXTERNAL TRANSDUCER A
1.000ADC TO BNC INPUT A
UN =
UL =                AL : -100.00%

WARNING! READING(S) OUTSIDE OF TOLERANCE
GO BACK      ABORT      SKIP

```

Figure 87. External Transducer Current Cal Point display

4. Wait one minute for the AL readings to settle and press ACCEPT.
5. Wait one minute for the readings to settle to  $0 \pm 0.1$  and press ACCEPT.
6. The following screen will display.

```

INPUT :      2ADC SOURCE L TO LOAD L
UN =
UL =                AL :   0.001%

ALL CALIBRATIONS SUCCESSFULLY COMPLETED
READINGS USING UPDATED CALIBRATION DATA
ACCEPT  GO BACK  ABORT  SAVE DATA

```

Figure 88. Calibrations Successful display

7. Press NEXT when the readings are within specification, then press SAVE DATA.
8. Press DONE.

The calibration date automatically updates whenever calibration is completed.

**Note:** *If you have not skipped any steps, then the present date will automatically replace the previous CALIBRATED date for the selected CURRENT INPUT.*

## Calibration Faults

In the event of a calibration fault, please check the connections to the calibrator and the analyzer before attempting calibration again. If you are unable to correct a fault condition, contact Xitron for assistance or for a return merchandise authorization (RMA) number. Refer to *User Information* in the front section of this guide for telephone number, address and e-mail address of Xitron Technologies Inc.

**Important Note:** *Opening the 2551/2551E Power Analyzer's case may void your warranty.*

## Calibration Connection Table

Internal Voltage Connections		External Voltage Connections	
Calibrator Lead	Rear Panel	Calibrator Lead*	Rear Panel
Negative	Chassis ground	Negative	Coax shield
Positive	SOURCE N & L (A)	Positive	EXTERNAL INPUT (BNC)— center conductor of coax

Internal Current Connections		External Current Connections	
Calibrator Lead	Rear Panel	Calibrator Lead*	Rear Panel
Negative	LOAD L (A)	Amp	External transducer
Positive	SOURCE L (A)	Volt	EXTERNAL INPUT (BNC)

---

\*Option for user: External calibration may be performed using a non-inductive external transducer.



---

# Appendix A - Physical Specifications

**Note:** *Specifications subject to change without notice.*

## Temperature & Humidity

Operating: 0°C to 45°C, <85% RH @ 40°C non-condensing

Storage: -30°C to 65°C, <95% RH @ 40°C non-condensing

## Size & Weight

Size: (HxWxD) 4.7" x 13.8" x 9.5" (11.94cm x 35.05cm x 24.13cm)

Weight: 7.5lbs. (3.4kg)

## Power Input

Voltage: 12VDC @ 1.5A minimum output.

Unit is supplied with one Xitron Technologies T5 free standing charger and a three prong AC power cord. This is a universal input 85-265Vrms, 40-400Hz, with a 2.5mm DC output plug and a three prong IEC320 AC inlet receptacle.



## Appendix B – Measurement Specifications

Unless otherwise indicated, all performance specifications are valid throughout the specified operating temperature range, for a period of 1 year, following a 15 minute warm-up period.

Where “typical” specifications are given, the specification is guaranteed for a typical application (115V/230Vrms with a current > 10% range), for further details regarding a specific application contact Xitron Technologies Inc. or its representative. Refer also to *Appendix A - Physical Specifications*.

**Note:** *Specifications subject to change without notice.*

### Power Source Capabilities (Option E only)

Output Voltage	+ and – 15V (within 0.5V), 2mm receptacles
Source Impedance	5Ω
Maximum Load	100mA

### Input Signal Capabilities

#### Receptacle Signal Terminals

Voltage (950V option)	2500Vpk for 1s, 675Vrms continuous, 950Vpk measurable
Voltage (1500V option)	2500Vpk for 1s, 875Vrms continuous, 1500Vpk measurable
Voltage (400V option)	2500Vpk for 1s, 425Vrms continuous, 400Vpk measurable
Current (8A option)	25Arms for 50ms, 10Arms continuous, 8Apk measurable
Current (40A option)	125Arms for 50ms, 25Arms continuous, 40Apk measurable

## BNC Signal Terminals (Option E only)

Common Mode	5Vpk maximum to chassis
Voltage	25Vpk for 50ms, 2.5Vrms continuous, 2.5Vpk measurable
Current	10Arms for 50ms, 2.5Arms continuous, 5Apk measurable

## Input Burden

All capacitances shown are typical values.

## 4mm Receptacle Signal Terminals

To Chassis (400V option)	243k $\Omega$    60pF
To Chassis (950V option)	600k $\Omega$    60pF
To Chassis (1500V option)	1M $\Omega$    60pF
Source to Load (8A option)	< 50m $\Omega$
Source to Load (40A option)	< 15m $\Omega$

## BNC Signal Terminals (Option E only)

### VOLTAGE Mode

To Chassis	100k $\Omega$    5pF
Signal	100k $\Omega$    5pF

### CURRENT Mode

To Chassis	50 $\Omega$    5pF
Signal	< 100m $\Omega$

## Measurement Accuracy

Unless otherwise shown, all percentages are percentage of the reading.

When including DC signal content, add DC measurement accuracy if total signal is less than 0.5% full-scale for option, or if DC component is greater than AC component.

When using an external current transducer, the specifications for that transducer should be added to the power Analyzer specifications to obtain the overall specifications.

**Voltage (400V option)**

DC	0.1% (0.25% above 250V) + 0.1V
0.02Hz to 20Hz range	0.1% (0.25% above 250V) + 0.02V + 0.1%/Hz add 0.15% below 0.04Hz if AC coupled add 0.075V for peak measurements
0.2Hz to 200Hz range	0.1% (0.25% above 250V) + 0.02V + 0.01%/Hz add 0.05% below 0.4Hz if AC coupled add 0.075V for peak measurements
2Hz to 2kHz range	0.1% (0.25% above 250V) + 0.02V + 0.001%/Hz add 0.05% below 4Hz if AC coupled add 0.075V for peak measurements
20Hz to 5kHz range	0.1% (0.25% above 250V) + 0.025V + 0.4%/kHz add 0.05% below 40Hz if AC coupled add 0.3V for peak measurements
20Hz to 100kHz range	0.1% (0.25% above 250V) + 0.05V + 0.02%/kHz add 0.1% below 40Hz if AC coupled add 0.5V for peak measurements
Common Mode	>70dB decreasing linearly to >40dB at 100kHz
Current to Voltage Crosstalk	typically negligible

**Voltage (950V option)**

DC	0.1% (0.25% above 400V) + 0.15V
0.02Hz to 20Hz range	0.1% (0.25% above 400V) + 0.025V + 0.1%/Hz add 0.15% below 0.04Hz if AC coupled add 0.1V for peak measurements
0.2Hz to 200Hz range	0.1% (0.25% above 400V) + 0.025V + 0.01%/Hz add 0.05% below 0.4Hz if AC coupled add 0.1V for peak measurements
2Hz to 2kHz range	0.1% (0.25% above 400V) + 0.03V + 0.001%/Hz add 0.05% below 4Hz if AC coupled add 0.15V for peak measurements
20Hz to 5kHz range	0.1% (0.25% above 400V) + 0.05V + 0.4%/kHz add 0.05% below 40Hz if AC coupled add 0.5V for peak measurements
20Hz to 100kHz range	0.1% (0.25% above 400V) + 0.1V + 0.02%/kHz add 0.1% below 40Hz if AC coupled add 1V for peak measurements

Common Mode	>70dB decreasing linearly to >40dB at 100kHz
Current to Voltage Crosstalk	typically negligible

### Voltage (1500V option)

DC	0.1% (0.25% above 500V) + 0.3V
0.02Hz to 20Hz range	0.1% (0.25% above 500V) + 0.05V + 0.1%/Hz add 0.15% below 0.04Hz if AC coupled add 0.2V for peak measurements
0.2Hz to 200Hz range	0.1% (0.25% above 500V) + 0.05V + 0.01%/Hz add 0.05% below 0.4Hz if AC coupled add 0.2V for peak measurements
2Hz to 2kHz range	0.1% (0.25% above 500V) + 0.075V + 0.001%/Hz add 0.05% below 4Hz if AC coupled add 0.3V for peak measurements
20Hz to 5kHz range	0.1% (0.25% above 500V) + 0.1V + 0.4%/kHz add 0.05% below 40Hz if AC coupled add 1V for peak measurements
20Hz to 100kHz range	0.1% (0.25% above 500V) + 0.15V + 0.04%/kHz add 0.1% below 40Hz if AC coupled add 2V for peak measurements
Common Mode	>70dB decreasing linearly to >35dB at 100kHz
Current to Voltage Crosstalk	typically negligible

### Internal Current (8A option)

DC	0.1% + 0.005A
0.02Hz to 20Hz range	0.1% + 0.005A + 0.1%/Hz add 0.15% below 0.04Hz if AC coupled add 0.02A for peak measurements
0.2Hz to 200Hz range	0.1% + 0.005A + 0.01%/Hz add 0.05% below 0.4Hz if AC coupled add 0.02A for peak measurements
2Hz to 2kHz range	0.1% + 0.005A + 0.001%/Hz add 0.05% below 4Hz if AC coupled add 0.02A for peak measurements
20Hz to 5kHz range	0.1% + 0.005A + 0.4%/kHz add 0.05% below 40Hz if AC coupled add 0.04A for peak measurements

20Hz to 100kHz range	below 10kHz : 0.1% + 0.01A + 0.4%/kHz 10kHz to 40kHz : 0.03A + 0.4%/kHz above 40kHz : 16% + 0.03A  add 0.1% below 40Hz if AC coupled add 0.1A for peak measurements
Common Mode	0.000001A / V / kHz (i.e. 0.0002A per kHz at 230V)
Phase (to Voltage)	0.1° + 0.05°/kHz add 1° for frequencies 1kHz to 10kHz

### Internal Current (40A option)

DC	0.1% + 0.025A
0.02Hz to 20Hz range	0.1% + 0.025A + 0.1%/Hz add 0.15% below 0.04Hz if AC coupled add 0.1A for peak measurements
0.2Hz to 200Hz range	0.1% + 0.025A + 0.01%/Hz add 0.05% below 0.4Hz if AC coupled add 0.1A for peak measurements
2Hz to 2kHz range	0.1% + 0.025A + 0.001%/Hz add 0.05% below 4Hz if AC coupled add 0.1A for peak measurements
20Hz to 5kHz range	0.1% + 0.025A + 0.4%/kHz add 0.05% below 40Hz if AC coupled add 0.2A for peak measurements
20Hz to 100kHz range	below 10kHz : 0.1% + 0.05A + 0.4%/kHz 10kHz to 40kHz : 0.15A + 0.4%/kHz above 40kHz : 16% + 0.15A  add 0.1% below 40Hz if AC coupled add 0.5A for peak measurements
Common Mode	0.000005A / V / kHz (i.e. 0.001A per kHz at 230V)
Phase (to Voltage)	0.1° + 0.05°/kHz add 1° for frequencies 1kHz to 10kHz

### External Current (E option, voltage input)

DC	0.1% + 0.0005V
0.02Hz to 20Hz range	0.1% + 0.0001V + 0.1%/Hz add 0.15% below 0.04Hz if AC coupled add 0.0005V for peak measurements

0.2Hz to 200Hz range	0.1% + 0.0001V + 0.01%/Hz add 0.05% below 0.4Hz if AC coupled add 0.0005V for peak measurements
2Hz to 2kHz range	0.1% + 0.0001V + 0.001%/Hz add 0.05% below 4Hz if AC coupled add 0.0005V for peak measurements
20Hz to 5kHz range	0.1% + 0.00015V + 0.4%/kHz add 0.05% below 40Hz if AC coupled add 0.0015V for peak measurements
20Hz to 100kHz range	0.1% + 0.00025V + 0.02%/kHz add 0.1% below 40Hz if AC coupled add 0.0025V for peak measurements
Common Mode	>60dB decreasing linearly to >40dB at 100kHz
Phase (to Voltage)	$0.1^\circ + 0.05^\circ/\text{kHz}$

### External Current (E option, current input)

DC	0.1% + 0.01A
0.02Hz to 20Hz range	0.1% + 0.002A + 0.1%/Hz add 0.15% below 0.04Hz if AC coupled add 0.01A for peak measurements
0.2Hz to 200Hz range	0.1% + 0.002A + 0.01%/Hz add 0.05% below 0.4Hz if AC coupled add 0.01A for peak measurements
2Hz to 2kHz range	0.1% + 0.002A + 0.001%/Hz add 0.05% below 4Hz if AC coupled add 0.01A for peak measurements
20Hz to 5kHz range	0.1% + 0.003A + 0.4%/kHz add 0.05% below 40Hz if AC coupled add 0.03A for peak measurements
20Hz to 100kHz range	0.1% + 0.005A + 0.02%/kHz add 0.1% below 40Hz if AC coupled add 0.05A for peak measurements
Phase (to Voltage)	$0.1^\circ + 0.05^\circ/\text{kHz}$

### VA

(Applied Voltage) x Current Accuracy + (Applied Current) x Voltage Accuracy



## Power Factor

Combination of phase and crosstalk specifications

At 115 or 230Vrms (current >10% range for option fitted) –

PF =	1.0000	0.9000	0.7000	0.5000	0.3000	0.1000	0.0000
@ 50/60Hz	0.0001	0.0008	0.0013	0.0016	0.0017	0.0018	0.0018
@ 400Hz	0.0001	0.0009	0.0015	0.0018	0.0020	0.0021	0.0021
@ 30kHz	0.0005	0.0218	0.0318	0.0341	0.0329	0.0295	0.0273
@ 100kHz	0.0056	0.0725	0.1014	0.1068	0.1015	0.0897	0.0822

## DC Power

(Applied Voltage) x Current Accuracy + (Applied Current) x Voltage Accuracy

## AC Power

Combination of (Voltage x Current Accuracy), (Current x Voltage Accuracy), and phase specifications

At 115 or 230Vrms (current >10% range for option fitted, external current) -

PF=	1.0000	0.9000	0.7000	0.5000	0.3000	0.1000	0.0000
@ 50/60Hz	0.2%	0.3%	0.4%	0.5%	0.8%	2%	0.2% VA
@ 400Hz	0.2%	0.3%	0.4%	0.6%	0.8%	2.3%	0.23% VA
@ 30kHz	1.5%	3.1%	4.8%	6.9%	11%	30%	3% VA
@ 100kHz	4.6%	9.9%	15%	20%	33%	10% VA	10% VA

## VAR

Combination of (Voltage x Current Accuracy), (Current x Voltage Accuracy), phase accuracy, and common-mode

At 115 or 230Vrms (current >10% range for option fitted, external current, accuracy % of VAR reading) -

PF =	1.0000	0.9000	0.7000	0.5000	0.3000	0.1000	0.0000
@ 50/60Hz	0.2% VA	1.1%	0.5%	0.3%	0.3%	0.2%	0.2%
@ 400Hz	0.2% VA	1.2%	0.5%	0.4%	0.3%	0.2%	0.2%
@ 30kHz	1.0% VA	13%	4.5%	2.8%	2.1%	1.6%	1.4%
@ 100kHz	5.0% VA	40%	14%	8.3%	6%	4.4%	4.2%

## Harmonics

In the following 'N' denotes a harmonic number.

Minimum Fundamental	1% of full-scale for selected synchronization source
Number Harmonics	50 or 40kHz/fundamental frequency (whichever smaller)
Absolute Harmonics	As signal accuracy + (0.05% x N)
Relative Harmonics	0.1% + 0.04%/kHz
Total Distortion	0.1% at line frequencies
Inter-Harmonic Phase	0.1° + 0.2°/kHz (harmonic > 0.1% full-scale)

### Frequency

Minimum Input	0.5% of range for Option for input selected
Measurement Accuracy	0.05% (sampling synchronized to within 0.01%)
Measurement Period	100ms or 1 cycle (whichever longer)

### Integrated Results

Accuracy of integrated result + 0.05% + 10ms

### Crest Factor

Accuracy	From accuracy of peak results
Range	1 to 999

### Form Factor

Accuracy	From accuracy of amplitude results
Range	1 to 999

### Load K-Factor

Accuracy	From accuracy of harmonics results, typical accuracy within 0.02 at line frequencies.
Range	1 to 999

### Waveforms

Number of points per cycle	400 (nominally 0.4° accuracy)
Amplitude Accuracy	As relevant peak accuracy

---

## History

Timing Accuracy	0.05% + 10ms
Timing Resolution	5% of a division
Result Accuracy	As the result
Filtering	Non-peak results averaged over 5% of a division, peak results have continuous coverage within each 5% of a division at all frequencies
Depth	10 divisions
Timing (per division)	0.4 seconds, 1 second, 2 seconds, 5 seconds, 10 seconds, 30 seconds, 1 minute, 3 minutes, 10 minutes, 30 minutes, 1 hour, 3 hours, 6 hours, 12 hours, 1 day (user selectable)