

The V165 is a single-width, C-size, register-based, VXIbus module that provides realtime processing for data collected from other modules within the VXI chassis.

TYPICAL APPLICATIONS

Wind tunnel data acquisition
Aerospace tests
Automotive tests
Acoustic tests
General-purpose signal analysis
High-speed control loops

V165 Digital Signal Processor



ATI-based DSP with 40 MFLOP processing power

FEATURES

- Performs FIR & IIR filtering
- Computes FFTs
- Performs signal averaging
- Executes limit checking
- Converts to engineering units
- Executes at 40 MFLOPS
- Performs 32/40-bit floating point operations
- Includes 1 to 16 Mbyte DRAM
- Has DMA capability
- Options for Digi-bus™ input and output data paths

GENERAL DESCRIPTION

The V165 is a single-width, C-size, register-based, VXIbus module that provides realtime processing for data collected from other modules within the VXI chassis. The processing power for this module is provided by the Texas Instruments TMS320C30 (C30) Digital Signal Processor (DSP). This DSP provides 40 MFLOP operation and its 32/40-bit floating-point arithmetic capabilities simplify the development of applications, eliminating the effects of scaling, normalization, and overflow. Implemented with low power CMOS, the C30 also provides 16- and 24-bit integer operations, IEEE floating-point conversion capability, a bit reversal addressing mode, eight 40-bit accumulators, two 32-bit timers, and a 64 x 32-bit instruction cache. It can implement FIR filters at 50 ns per tap and compute a 1024-point complex FFT in 3.04 ms.

The C30 has two blocks of 1K x 32 single-cycle, dual-access, on-chip RAM. A range of 1 to 16 Mbytes of dual-ported RAM is also provided on the module. All dual-access memory is addressable from the VXIbus as well as by the DSP. This allows application programs and data to be downloaded from the host computer and to dynamically change as conditions require. Instructions and data can arbitrarily reside in either the on-chip or off-chip memory.

Data to be manipulated by the DSP may be obtained from various sources and stored in various destinations. The data may be read or written by the V165 using Direct Memory Access (DMA). The V165 can become a master on the VXIbus and transfer data to and from other VXIbus modules within the chassis. Data may also be sent into and out of the V165 using the VXI Local Bus. For the V165-Bxy 1 option, this module supports a KineticSystems-developed Local Bus interface and protocol called Digi-bus™. Digi-bus provides the mechanism to transfer digital data between adjacent modules at high speed without degrading the performance of the VXI system bus or introducing latency from "slow responding" VXIbus modules within the chassis.

Digi-bus data enters the V165 from the module on its right (the next higher numbered slot) and is passed to a selection mechanism on the V165 Digi-bus mezzanine board. The V165 can be programmed to accept all the incoming data or only selected subsets. The selected data is then available to the DSP through a 32 kword buffer. Circuitry on the mezzanine board allows the DSP to send data to the module on its left (the next lower numbered slot) by writing the word to a register on the mezzanine board.

The V165 can synchronize with other modules in the chassis by the use of its VXIbus triggers and interrupts. The V165 can be programmed to generate any number of simultaneous VXI triggers using the Synchronous Trigger protocol and to generate a VXI interrupt on any one of the eight VXI interrupt sources. The V165 can also be programmed to interrupt the DSP on the occurrence of a selected VXI trigger or when a VXI request is made with a write to a Generate DSP Interrupt register in A32 space on the V165. In addition, the C30 DSP provides two internal, 32-bit timers which can be programmed for periodic interrupts.

A 32-bit digital input register, which is directly readable by the DSP, can be written from the front-panel connector. Reduced data and results from the DSP's operation can be sent either to other VXI modules via DMA or to other Digi-bus equipped KineticSystems VXI modules downstream from the V165. Also available at the front connector are two DSP serial ports capable of 7.69 Mbit/s operation. These ports can be used to transmit or receive serial data between this module and an external source, such as another V165 DSP module, for multiprocessor communication.

The V165 supports both static and dynamic configuration. Access to the DSP and its associated memory is through memory locations selected by the Offset Register within the VXIbus Configuration Register set. Access to these registers and memory is accomplished within A32/A16 address space using D32/D16 transfers.

V165 Block Diagram

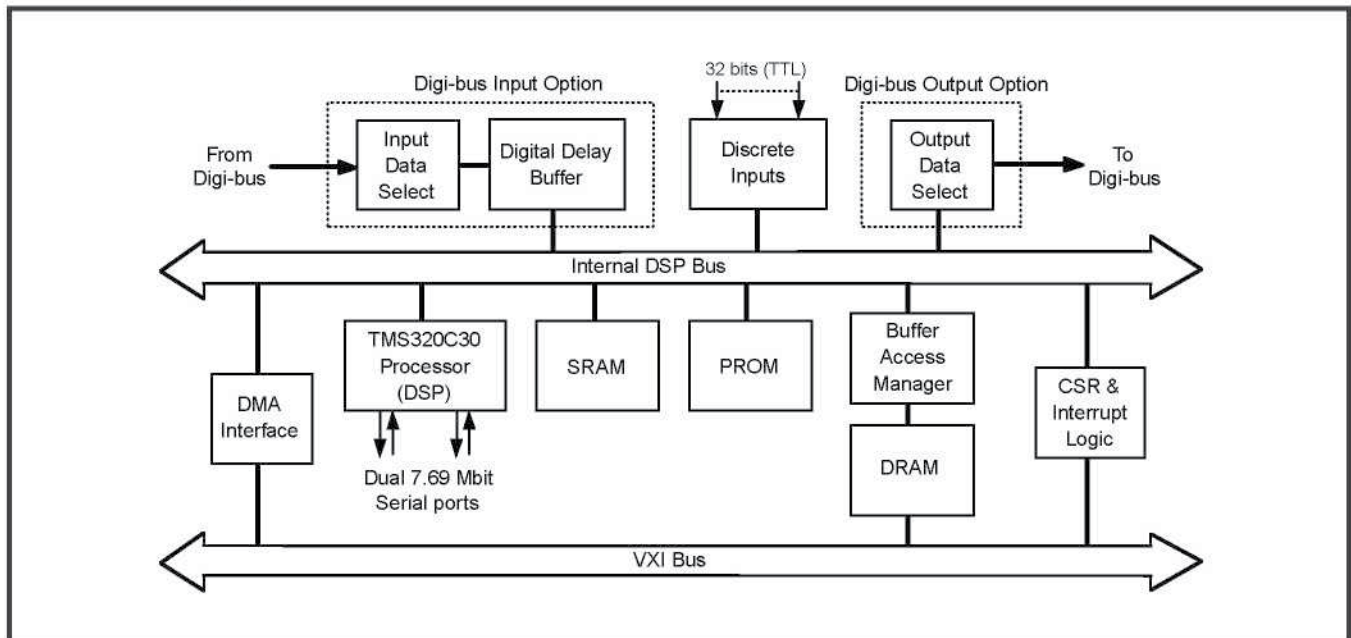



CROSS-DEVELOPEMENT SOFTWARE AND UTILITIES

The Texas Instruments TMS320 Floating-Point DSP Optimizing C -compiler, assembler, linker, emulator, and simulator are available to support application programming. This software is available for the PC/MS-DOS, VAX/VMS, and SUN-3/UNIX platforms. We also support Momentum Data Systems' QEDesign 1000 Digital Filter Design package. This package allows the user to design FIR and IIR digital filters for the V165. This software is available for the PC under Windows as well as for SUN workstations.

KineticSystems has developed a support library for the V165 DSP which offers a high-level interface to the module's hardware features. The library functions include DMA read and write, Digi-bus acceptor and source, VXI trigger interrupt service, VXI trigger and interrupt source, and timer interrupt service. Other V165 hardware features, such as the front-panel TTL inputs and the 8-bit LED status register, also have interface functions in the support library. The library distribution also includes a library header file with prototypes for all the functions, working code examples for each hardware group, and utilities which download the user's 'C30 application code to the V165 and execute it.

When used in conjunction with the Texas Instruments TMS320 Floating-Point DSP Optimizing C-Compiler package (Model AB11-DPA1), the support library can simplify the development of DSP applications for the V165. Programmers can establish the data path into and out of the V165 with DMA or Digi-bus function calls, leaving them more time to implement signal processing algorithms. While C should be the language of choice, the compiler package includes a 'C30 assembler (and other programmer's tools such as a linker and archiver) when the application must execute as quickly as possible. Both the compiler and the library support Interrupt Service Routines (ISRs) are written in C. The compiler generates entry and exit code that preserves the machine environment. The library simplifies the use of VXI and timer interrupts by setting up the interrupt vector and the interrupt masks, leaving the programmer to concentrate on the application. The distribution disk contains source and object code for VXI trigger and DSP timer ISR examples to facilitate development.

Please contact KineticSystems or your local representative for additional information about these software products.

Item	Specification
DSP Cycle time Operations per second Instructions per second Instruction cache On-chip RAM Timers	50 ns 40 MFLOPS 20 MIPS 64x32 Two blocks of 1Kx 32 Two, 32 bits each
DSP Support Circuitry Dual-ported dynamic RAM Static RAM ROM DMA Digi-bus input port Digi-bus output port	1 to 16 Mbyte, 80 ns pipelined-access 8 kbyte to 128 kbyte, 0 wait state; optional 128 kbyte, 1 wait state 32 kbyte to 128 kbyte, 1 wait state Supports 8, 16, and 32-bit data transfers 32 kbyte x 16-bit sample buffer 16-bit samples configurable via DSP
Discrete Digital Inputs Number of inputs Input signal level Input signal logic level Input signal termination	32 TTL High true (0 V read by DSP as a logic "0") Pulled up to +5 V through 4.7 k Ω resistors
Serial Ports Number of ports Port direction Bits per serial word Maximum serial rate	2 Bi-directional 8, 16, 24, or 32 7.69 Mbit/s
Connector Type	50P High Density
Power Requirements +5V -5.2 V -2V	6.8 A 125 mA 125 mA
Environmental and Mechanical Temperature range Operational Storage Relative humidity Cooling requirements Dimensions Front-panel potential	0°C to +50°C -25°C to +75°C 0 to 85%, non-condensing to +40°C 10 CFM 340 mm x 233.35 mm x 30.48 mm (C-size VXIbus) Chassis ground



Related Products

- Model 5819-Bxyz Cable—50S High Density to Unterminated
- Model 5819-Dxyz Cable—50S High Density to 50S Amphenol Ribbon
- Model 5819-Fxyz Cable—50S High Density to 50P High Density
- Model 5819-Gxyz Cable—50S High Density to 50S High Density
- Model AB11 -DPA1 V165 TI Cross-development Package for MS-DOS
- Model AB12-DPA1 V165 Full Development Package for MS-DOS
(Cross-development routines plus KineticSystems Software Support Library)

Please contact the factory for information on software packages for other operating systems.

- Model V110 4 to 128 Megabyte Memory
- Model V207 16-bit, 500,000 Sample/second ADC Subsystem
- Model V208 16-bit, 100,000 Sample/second ADC Subsystem
- Model V285 8 or 16-channel, 16-bit, 500 kHz DAC/Waveform Generator
- Model V387 128-channel Discrete Input/Output
- Model V765 Rack-mount Termination Panel

ORDERING INFORMATION

MODEL	DESCRIPTION
V165-wxyz	Digital Signal Processor
w: Option cards A = no options installed B = Digi-bus™ Local Bus option x: DRAM Size A = 1 Mbyte DRAM B = 4 Mbyte DRAM C = 8 Mbyte DRAM D = 16 Mbyte DRAM y: SRAM Size A = 8 kbyte SRAM B = 32 kbyte SRAM C = 128 kbyte SRAM D = 256 kbyte SRAM	
V165-0001	Digi-bus Factory Upgrade

KineticSystems Company, LLC

900 N. State St.
Lockport, IL 60441-2200

Toll-Free (US and Canada):

phone 1-800-DATA NOW
1-800-328-2669

Direct:

phone +1-815-838-0005
fax +1-815-838-4424

Email:

mkt-info@kscorp.com

To find your local sales representative or distributor or to learn more about KineticSystems' products visit:

www.kscorp.com